

## ST 3000 Smart Pressure Transmitter Series 100 Differential Pressure Models

34-ST-03-60  
10/2004

### Specification and Model Selection Guide

STD110	0 to 10 inH <sub>2</sub> O	0 to 25 mbar
STD120	0 to 400 inH <sub>2</sub> O	0 to 1,000 mbar
STD125	0 to 600 inH <sub>2</sub> O	0 to 1,500 mbar
STD130	0 to 100 psi	0 to 7,000 mbar
STD170	0 to 3000 psi	0 to 210,000 mbar

#### Introduction

In 1983, Honeywell introduced the first Smart Pressure Transmitter—the ST 3000®. In 1989, Honeywell launched the first all digital, bi-directional protocol for smart field devices. Today, its ST 3000 Series 100 Differential Pressure Transmitters continue to bring proven “smart” technology to a wide spectrum of pressure measurement applications, from furnace combustion airflow rate to hydrostatic tank gauging. The ST 3000 S100 Differential Pressure Transmitter can be used with any primary flow element to provide proven, repeatable flow measurement.

All ST 3000 transmitters can provide a 4-20 mA output, Honeywell Digitally Enhanced (DE) output, HART® output, or FOUNDATION™ Fieldbus output. When digitally integrated with Honeywell’s Process Knowledge System™, EXPERION PKS™, ST 3000 instruments provide a more accurate process variable as well as advanced diagnostics.

Honeywell’s high-performance ST 3000 S100 transmitters lead the industry in:

- Accuracy
- Stability
- Reliability
- Rangeability
- Warranty

Includes Lifetime™ Transmitters:

- Accuracy = +/-0.0375%
- Stability = +/-0.01% per year
- Reliability = 470 years MTBF
- Rangeability = 400 to 1
- Lifetime Warranty = 15 years



**Figure 1**—Series 100 Differential Pressure Transmitters feature proven piezoresistive sensor technology.

The devices provide comprehensive self-diagnostics to help users maintain high uptime, meet regulatory requirements, and attain high quality standards. S100 transmitters are ideal for critical applications, such as custody transfer of natural gas and energy and material balances, where accuracy and stability are of the utmost importance.

"Our commitment to Honeywell field instruments is based on seamless integration with our Honeywell system and the enhanced fault detection that the Honeywell DE protocol offers. Honeywell instruments also offer us a better way of ensuring database integrity over simple analog instruments. In addition, Honeywell's high-quality support has enabled us to better implement solutions to some of our more difficult problems. We have used Honeywell differential pressure smart transmitters for the past eight years. Based on their accuracy and low failure rates, we are now targeting critical flow applications that require the robustness that these transmitters bring."

DCS Systems Engineer  
International Integrated Oil Company

## Description

The ST 3000 transmitter can replace any 4 to 20 mA output transmitter in use today and operates over a standard two-wire system.

The measuring means is a piezoresistive sensor, which actually contains three sensors in one. It contains a differential pressure sensor, a temperature sensor, and a static pressure sensor.

Microprocessor-based electronics provide higher span-turndown ratio, improved temperature and pressure compensation, and improved accuracy.

The transmitter's meter body and electronics housing resist shock, vibration, corrosion, and moisture. The electronics housing contains a compartment for the single-board electronics, which is isolated from an integral junction box. The single-board electronics is replaceable and interchangeable with any other ST 3000 Series 100 or Series 900 model transmitter.

Like other Honeywell transmitters, the ST 3000 features two-way communication between the operator and the transmitter through our Smart Field Configurator (SFC). You can connect the SFC anywhere that you can access the transmitter signal lines.

The SCT 3000 Smartline<sup>®</sup> Configuration Toolkit provides an easy way to configure instruments using a personal computer. The toolkit enables configuration of devices before shipping or installation. The SCT 3000 can operate in the offline mode to configure an unlimited number of devices. The database can then be loaded downline during commissioning.

## Features

- Choice of linear or square root output conformity is a simple configuration selection.
- Direct digital integration with Experion PKS and other control systems provides local measurement accuracy to the system level without adding typical A/D and D/A converter inaccuracies.
- Unique piezoresistive sensor automatically compensates input for temperature and static pressure. Added "smart" features include configuring lower and upper range values, simulating accurate analog output, and selecting preprogrammed engineering units for display.
- Smart transmitter capabilities with local or remote interfacing means significant manpower efficiency improvements in commissioning, start-up, and ongoing maintenance functions.

## Specifications

### Operating Conditions – All Models

Parameter	Reference Condition		Rated Condition		Operative Limits		Transportation and Storage	
	°C	°F	°C	°F	°C	°F	°C	°F
<b>Ambient Temperature</b>								
STD110	25±1	77±2	-15 to 65	5 to 150	-40 to 70	-40 to 158	-40 to 70	-40 to 158
STD125	25±1	77±2	-40 to 85	-40 to 185	-40 to 85	-40 to 185	-55 to 125	-67 to 257
STD120, STD130, STD170	25±1	77±2	-40 to 85	-40 to 185	-40 to 93	-40 to 200	-55 to 125	-67 to 257
<b>Meter Body Temperature</b>								
STD110	25±1	77±2	-15 to 65	5 to 150	-40 to 70	-40 to 158	-40 to 70	-40 to 158
STD125	25±1	77±2	-40 to 85	-40 to 185	-40 to 85	-40 to 185	-55 to 125	-67 to 257
STD120, STD130, STD170	25±1	77±2	-40 to 110*	-40 to 230*	-40 to 125	-40 to 257	-55 to 125	-67 to 257
<b>Humidity</b> %RH	10 to 55		0 to 100		0 to 100		0 to 100	
<b>Vac. Region – Min. Pressure</b> All Models Except STD110 <b>mmHg absolute</b> <b>inH<sub>2</sub>O absolute</b>	Atmospheric Atmospheric		25 13		2 (short term **) 1 (short term **)			
<b>Supply Voltage, Current, and Load Resistance</b>	<b>Voltage Range:</b> 10.8 to 42.4 Vdc at terminals <b>Current Range:</b> 3.0 to 21.8 mA <b>Load Resistance:</b> 0 to 1440 ohms (as shown in Figure 2)							
<b>Maximum Allowable Working Pressure (MAWP)</b>  (ST 3000 products are rated to Maximum Allowable Working Pressure. MAWP depends on Approval Agency and transmitter materials of construction.)	STD110 = 50 psi, 3.45 bar ***STD120, STD125, STD130 and STD170 = 4,500 psi, 310 bar Static Pressure Limit = Maximum Allowable Working Pressure (MAWP) = Overpressure Limit for ST 3000 Differential Pressure Transmitters							

\* For CTFE fill fluid, the rating is -15 to 110°C (5 to 230°F). \*\* Short term equals 2 hours at 70°C (158 °F)

\*\*\* MAWP applies for temperature range -40 to 125 deg. C. However, Static Pressure Limit is de-rated to 3000 psi from -26 deg C. to -40 deg. C. Use of graphite o-rings de-rates transmitter to 3,625 psi. Use of Adaptor with graphite o-rings de-rates transmitter to 3,000 psi.

- Consult factory for MAWP of ST 3000 transmitters with CSA approval.

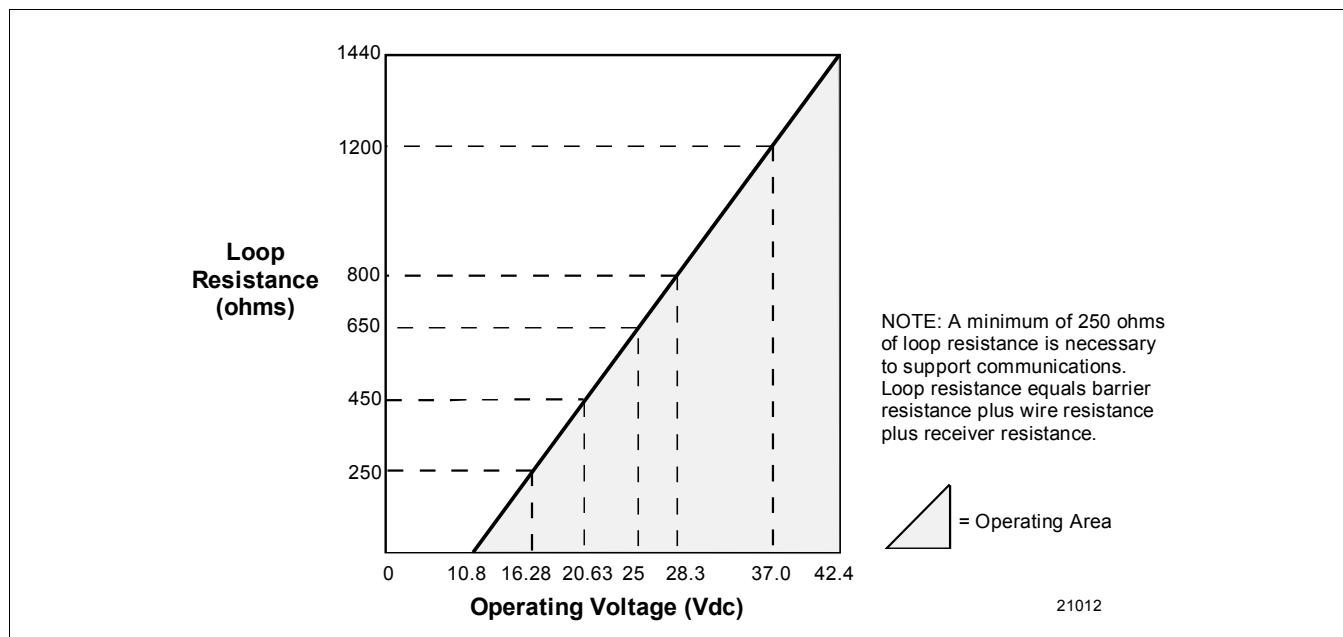

**Figure 2** - Supply voltage and loop resistance chart.

Performance Under Rated Conditions\* - Model STD110 (0 to 10 inH<sub>2</sub>O)

Parameter	Description
<b>Upper Range Limit</b> inH <sub>2</sub> O mbar	10 (39.2°F/4°C is standard reference temperature for inH <sub>2</sub> O range.) 25
<b>Minimum Span</b> inH <sub>2</sub> O mbar	0.4 1
<b>Turndown Ratio</b>	25 to 1
<b>Zero Elevation and Suppression</b>	No limit except minimum span within ±100% URL.
<b>Accuracy</b> (Reference – Includes combined effects of linearity, hysteresis, and repeatability)  • Accuracy includes residual error after averaging successive readings.  • For FOUNDATION Fieldbus use Digital Mode specifications. For HART use Analog Mode specifications.	<b>In Analog Mode:</b> ±0.1% of calibrated span or upper range value (URV), whichever is greater, terminal based. For URV below reference point (1.5 inH <sub>2</sub> O), accuracy equals: $\pm 0.025 + 0.075 \left( \frac{1.5 \text{ inH}_2\text{O}}{\text{span inH}_2\text{O}} \right)$ or $\pm 0.025 + 0.075 \left( \frac{3.75 \text{ mbar}}{\text{span mbar}} \right)$ in % span  <b>In Digital Mode:</b> ±0.0875% of calibrated span or upper range value (URV), whichever is greater, terminal based. For URV below reference point (1.5 inH <sub>2</sub> O), accuracy equals: $\pm 0.125 + 0.075 \left( \frac{1.5 \text{ inH}_2\text{O}}{\text{span inH}_2\text{O}} \right)$ or $\pm 0.0125 + 0.075 \left( \frac{3.75 \text{ mbar}}{\text{span mbar}} \right)$ in % span
<b>Zero Temperature Effect per 28°C (50°F)</b>	<b>In Analog Mode:</b> ±0.2625% of span. For URV below reference point (10 inH <sub>2</sub> O), effect equals: $\pm 0.0125 + 0.25 \left( \frac{10 \text{ inH}_2\text{O}}{\text{span inH}_2\text{O}} \right)$ or $\pm 0.0125 + 0.25 \left( \frac{25 \text{ mbar}}{\text{span mbar}} \right)$ in % span  <b>In Digital Mode:</b> ±0.25% of span. For URV below reference point (10 inH <sub>2</sub> O), effect equals: $\pm 0.25 \left( \frac{10 \text{ inH}_2\text{O}}{\text{span inH}_2\text{O}} \right)$ or $\pm 0.25 \left( \frac{25 \text{ mbar}}{\text{span mbar}} \right)$ in % span
<b>Combined Zero and Span Temperature Effect per 28°C (50°F)</b>	<b>In Analog Mode:</b> ±0.4875% of span. For URV below reference point (10 inH <sub>2</sub> O), effect equals: $\pm 0.2375 + 0.25 \left( \frac{10 \text{ inH}_2\text{O}}{\text{span inH}_2\text{O}} \right)$ or $\pm 0.2375 + 0.25 \left( \frac{25 \text{ mbar}}{\text{span mbar}} \right)$ in % span  <b>In Digital Mode:</b> ±0.4625% of span. For URV below reference point (10 inH <sub>2</sub> O), effect equals: $\pm 0.2125 + 0.25 \left( \frac{10 \text{ inH}_2\text{O}}{\text{span inH}_2\text{O}} \right)$ or $\pm 0.2125 + 0.25 \left( \frac{25 \text{ mbar}}{\text{span mbar}} \right)$ in % span

\* Performance specifications are based on reference conditions of 25°C (77°F), zero (0) static pressure, 10 to 55% RH, and 316 Stainless Steel barrier diaphragm.

### Performance Under Rated Conditions\* - Model STD120 (0 to 400 inH<sub>2</sub>O)

Parameter	Description
<b>Upper Range Limit</b> inH <sub>2</sub> O mbar	400 (39.2°F/4°C is standard reference temperature for inH <sub>2</sub> O range.) 1000
<b>Minimum Span</b> inH <sub>2</sub> O mbar	1      Note: Recommended minimum span in square root mode is 20 inH <sub>2</sub> O (50 mbar). 2.5
<b>Turndown Ratio</b>	400 to 1
<b>Zero Elevation and Suppression</b>	No limit except minimum span within ±100% URL. Specifications valid from –5 to +100% URL.
<b>Accuracy</b> (Reference – Includes combined effects of linearity, hysteresis, and repeatability) • Accuracy includes residual error after averaging successive readings. • For FOUNDATION Fieldbus use Digital Mode specifications. For HART use Analog Mode specifications.	<b>In Analog Mode:</b> ±0.075% of calibrated span or upper range value (URV), whichever is greater, terminal based. For URV below reference point (25 inH <sub>2</sub> O), accuracy equals: $\pm 0.025 + 0.05 \left( \frac{25 \text{ inH}_2\text{O}}{\text{span inH}_2\text{O}} \right)$ or $\pm 0.025 + 0.05 \left( \frac{62 \text{ mbar}}{\text{span mbar}} \right)$ in % span  * For High Accuracy (HA) option: +/- 0.0375% of calibrated span or upper range value (URV), whichever is greater, terminal based. <b>In Digital Mode:</b> ±0.0625% of calibrated span or upper range value (URV), whichever is greater, terminal based. For URV below reference point (25 inH <sub>2</sub> O), accuracy equals: $\pm 0.0125 + 0.05 \left( \frac{25 \text{ inH}_2\text{O}}{\text{span inH}_2\text{O}} \right)$ or $\pm 0.0125 + 0.05 \left( \frac{62 \text{ mbar}}{\text{span mbar}} \right)$ in % span  * For High Accuracy (HA) option: +/- 0.035% of calibrated span or upper range value (URV), whichever is greater, terminal based.
<b>Zero Temperature Effect per 28°C 50°F)</b>	<b>In Analog Mode:</b> ±0.0625% of span. For URV below reference point (50 inH <sub>2</sub> O), effect equals: $\pm 0.0125 + 0.05 \left( \frac{50 \text{ inH}_2\text{O}}{\text{span inH}_2\text{O}} \right)$ or $\pm 0.0125 + 0.05 \left( \frac{125 \text{ mbar}}{\text{span mbar}} \right)$ in % span <b>In Digital Mode:</b> ±0.05% of span. For URV below reference point (50 inH <sub>2</sub> O), effect equals: $\pm 0.05 \left( \frac{50 \text{ inH}_2\text{O}}{\text{span inH}_2\text{O}} \right)$ or $\pm 0.05 \left( \frac{125 \text{ mbar}}{\text{span mbar}} \right)$ in % span
<b>Combined Zero and Span Temperature Effect per 28°C (50°F)</b>	<b>In Analog Mode:</b> ±0.10% of span. For URV below reference point (50 inH <sub>2</sub> O), effect equals: $\pm 0.05 + 0.05 \left( \frac{50 \text{ inH}_2\text{O}}{\text{span inH}_2\text{O}} \right)$ or $\pm 0.05 + 0.05 \left( \frac{125 \text{ mbar}}{\text{span mbar}} \right)$ in % span <b>In Digital Mode:</b> ±0.075% of span. For URV below reference point (50 inH <sub>2</sub> O), effect equals: $\pm 0.025 + 0.05 \left( \frac{50 \text{ inH}_2\text{O}}{\text{span inH}_2\text{O}} \right)$ or $\pm 0.025 + 0.05 \left( \frac{125 \text{ mbar}}{\text{span mbar}} \right)$ in % span
<b>Zero Static Pressure Effect per 1000 psi (70 bar)</b>	±0.075% of span. For URV below reference point (50 inH <sub>2</sub> O), effect equals: $\pm 0.0125 + 0.0625 \left( \frac{50 \text{ inH}_2\text{O}}{\text{span inH}_2\text{O}} \right)$ or $\pm 0.0125 + 0.0625 \left( \frac{125 \text{ mbar}}{\text{span mbar}} \right)$ in % span
<b>Combined Zero and Span Static Pressure Effect per 1000 psi (70 bar)</b>	±0.15% of span. For URV below reference point (50 inH <sub>2</sub> O), effect equals: $\pm 0.0875 + 0.0625 \left( \frac{50 \text{ inH}_2\text{O}}{\text{span inH}_2\text{O}} \right)$ or $\pm 0.0875 + 0.0625 \left( \frac{125 \text{ mbar}}{\text{span mbar}} \right)$ in % span
<b>Stability</b>	±0.01% of URL per year for lifetime

\* Performance specifications are based on reference conditions of 25°C (77°F), zero (0) static pressure, 10 to 55% RH, and 316 Stainless Steel barrier diaphragm.

Performance Under Rated Conditions\* - Model STD125 (0 to 600 inH<sub>2</sub>O)

Parameter	Description
Upper Range Limit      inH <sub>2</sub> O mbar	600 (39.2°F/4°C is standard reference temperature for inH <sub>2</sub> O range.) 1500
Minimum Span            inH <sub>2</sub> O mbar	25 62.2
Turndown Ratio	24 to 1
Zero Elevation and Suppression	No limit except minimum span within 0 to 100% URL.
<b>Accuracy</b> (Reference – Includes combined effects of linearity, hysteresis, and repeatability) <ul style="list-style-type: none"> <li>• Accuracy includes residual error after averaging successive readings.</li> <li>• For FOUNDATION Fieldbus use Digital Mode specifications. For HART use Analog Mode specifications.</li> </ul>	<b>In Analog Mode:</b> ±0.075% of calibrated span or upper range value (URV), whichever is greater, terminal based. For URV below reference point (25 inH <sub>2</sub> O), accuracy equals: $\pm 0.0375 + 0.0375 \left( \frac{25 \text{ inH}_2\text{O}}{\text{span inH}_2\text{O}} \right)$ or $\pm 0.0375 + 0.0375 \left( \frac{62 \text{ mbar}}{\text{span mbar}} \right)$ in % span  <b>In Digital Mode:</b> ±0.05% of calibrated span or upper range value (URV), whichever is greater, terminal based. For URV below reference point (25 inH <sub>2</sub> O), accuracy equals: $\pm 0.0125 + 0.0375 \left( \frac{25 \text{ inH}_2\text{O}}{\text{span inH}_2\text{O}} \right)$ or $\pm 0.0125 + 0.0375 \left( \frac{62 \text{ mbar}}{\text{span mbar}} \right)$ in % span
Zero Temperature Effect per 28°C (50°F)	<b>In Analog Mode:</b> ±0.0625% of span. For URV below reference point (50 inH <sub>2</sub> O), effect equals: $\pm 0.0125 + 0.05 \left( \frac{50 \text{ inH}_2\text{O}}{\text{span inH}_2\text{O}} \right)$ or $\pm 0.0125 + 0.05 \left( \frac{125 \text{ mbar}}{\text{span mbar}} \right)$ in % span  <b>In Digital Mode:</b> ±0.05% of span. For URV below reference point (50 inH <sub>2</sub> O), effect equals: $\pm 0.05 \left( \frac{50 \text{ inH}_2\text{O}}{\text{span inH}_2\text{O}} \right)$ or $\pm 0.05 \left( \frac{125 \text{ mbar}}{\text{span mbar}} \right)$ in % span
Combined Zero and Span Temperature Effect per 28°C (50°F)	<b>In Analog Mode:</b> ±0.10% of span. For URV below reference point (50 inH <sub>2</sub> O), effect equals: $\pm 0.05 + 0.05 \left( \frac{50 \text{ inH}_2\text{O}}{\text{span inH}_2\text{O}} \right)$ or $\pm 0.05 + 0.05 \left( \frac{125 \text{ mbar}}{\text{span mbar}} \right)$ in % span  <b>In Digital Mode:</b> ±0.075% of span. For URV below reference point (50 inH <sub>2</sub> O), effect equals: $\pm 0.025 + 0.05 \left( \frac{50 \text{ inH}_2\text{O}}{\text{span inH}_2\text{O}} \right)$ or $\pm 0.025 + 0.05 \left( \frac{125 \text{ mbar}}{\text{span mbar}} \right)$ in % span
Zero Static Pressure Effect per 1000 psi (70 bar)	±0.075% of span. For URV below reference point (50 inH <sub>2</sub> O), effect equals: $\pm 0.0125 + 0.0625 \left( \frac{50 \text{ inH}_2\text{O}}{\text{span inH}_2\text{O}} \right)$ or $\pm 0.0125 + 0.0625 \left( \frac{125 \text{ mbar}}{\text{span mbar}} \right)$ in % span
Combined Zero and Span Static Pressure Effect per 1000 psi (70 bar)	±0.20% of span. For URV below reference point (50 inH <sub>2</sub> O), effect equals: $\pm 0.1375 + 0.0625 \left( \frac{50 \text{ inH}_2\text{O}}{\text{span inH}_2\text{O}} \right)$ or $\pm 0.1375 + 0.0625 \left( \frac{125 \text{ mbar}}{\text{span mbar}} \right)$ in % span
Stability	±0.015% URL per year

\* Performance specifications are based on reference conditions of 25°C (77°F), zero (0) static pressure, 10 to 55% RH, and 316 Stainless Steel barrier diaphragm.

## Performance Under Rated Conditions\* - Model STD130 (0 to 100 psi)

Parameter	Description
Upper Range Limit psi bar	100 7
Minimum Span psi bar	5 0.35
Turndown Ratio	20 to 1
Zero Elevation and Suppression	No limit except minimum span within -18 and +100% URL. Specifications valid from -5 to +100% URL.
<b>Accuracy</b> (Reference – Includes combined effects of linearity, hysteresis, and repeatability) <ul style="list-style-type: none"> <li>Accuracy includes residual error after averaging successive readings.</li> <li>For FOUNDATION Fieldbus use Digital Mode specifications. For HART use Analog Mode specifications.</li> </ul>	<b>In Analog Mode:</b> $\pm 0.075\%$ of calibrated span or upper range value (URV), whichever is greater, terminal based. For URV below reference point (15 psi), accuracy equals: $\pm 0.025 + 0.05 \left( \frac{15 \text{ psi}}{\text{span psi}} \right)$ or $\pm 0.025 + 0.05 \left( \frac{1 \text{ bar}}{\text{span bar}} \right)$ in % span  <b>In Digital Mode:</b> $\pm 0.0625\%$ of calibrated span or upper range value (URV), whichever is greater, terminal based. For URV below reference point (15 psi), accuracy equals: $\pm 0.0125 + 0.05 \left( \frac{15 \text{ psi}}{\text{span psi}} \right)$ or $\pm 0.0125 + 0.05 \left( \frac{1 \text{ bar}}{\text{span bar}} \right)$ in % span
Zero Temperature Effect per 28°C (50°F)	<b>In Analog Mode:</b> $\pm 0.0625\%$ of span. For URV below reference point (30 psi), effect equals: $\pm 0.0125 + 0.05 \left( \frac{30 \text{ psi}}{\text{span psi}} \right)$ or $\pm 0.0125 + 0.05 \left( \frac{2 \text{ bar}}{\text{span bar}} \right)$ in % span  <b>In Digital Mode:</b> $\pm 0.05\%$ of span. For URV below reference point (30 psi), effect equals: $\pm 0.05 \left( \frac{30 \text{ psi}}{\text{span psi}} \right)$ or $\pm 0.05 \left( \frac{2 \text{ bar}}{\text{span bar}} \right)$ in % span
Combined Zero and Span Temperature Effect per 28°C (50°F)	<b>In Analog Mode:</b> $\pm 0.10\%$ of span. For URV below reference point (30 psi), effect equals: $\pm 0.05 + 0.05 \left( \frac{30 \text{ psi}}{\text{span psi}} \right)$ or $\pm 0.05 + 0.05 \left( \frac{2 \text{ bar}}{\text{span bar}} \right)$ in % span  <b>In Digital Mode:</b> $\pm 0.075\%$ of span. For URV below reference point (30 psi), effect equals: $\pm 0.025 + 0.05 \left( \frac{30 \text{ psi}}{\text{span psi}} \right)$ or $\pm 0.025 + 0.05 \left( \frac{2 \text{ bar}}{\text{span bar}} \right)$ in % span
Zero Static Pressure Effect per 1000 psi (70 bar)	$\pm 0.075\%$ of span. For URV below reference point (30 psi), effect equals: $\pm 0.0125 + 0.0625 \left( \frac{30 \text{ psi}}{\text{span psi}} \right)$ or $\pm 0.0125 + 0.0625 \left( \frac{2 \text{ bar}}{\text{span bar}} \right)$ in % span
Combined Zero and Span Static Pressure Effect per 1000 psi (70 bar)	$\pm 0.15\%$ of span. For URV below reference point (30 psi), effect equals: $\pm 0.0875 + 0.0625 \left( \frac{30 \text{ psi}}{\text{span psi}} \right)$ or $\pm 0.0875 + 0.0625 \left( \frac{2 \text{ bar}}{\text{span bar}} \right)$ in % span
Stability	$\pm 0.04\%$ of URL per year.

\* Performance specifications are based on reference conditions of 25°C (77°F), zero (0) static pressure, 10 to 55% RH, and 316 Stainless Steel barrier diaphragm.

## Performance Under Rated Conditions\* - Model STD170 (0 to 3000 psi)

Parameter	Description
Upper Range Limit psi bar	3000 210
Minimum Span psi bar	100 7
Turndown Ratio	30 to 1
Zero Elevation and Suppression	No limit except minimum span within -0.6 and +100% URL. Specifications valid over this range.
<b>Accuracy</b> (Reference – Includes combined effects of linearity, hysteresis, and repeatability) <ul style="list-style-type: none"> <li>Accuracy includes residual error after averaging successive readings.</li> <li>For FOUNDATION Fieldbus use Digital Mode specifications. For HART use Analog Mode specifications.</li> </ul>	<b>In Analog Mode:</b> $\pm 0.15\%$ of calibrated span or upper range value (URV), whichever is greater, terminal based. For URV below reference point (300 psi), accuracy equals: $\pm 0.05 + 0.10 \left( \frac{300 \text{ psi}}{\text{span psi}} \right)$ or $\pm 0.05 + 0.10 \left( \frac{21 \text{ bar}}{\text{span bar}} \right)$ in % span  <b>In Digital Mode:</b> $\pm 0.125\%$ of calibrated span or upper range value (URV), whichever is greater, terminal based. For URV below reference point (300 psi), accuracy equals: $\pm 0.025 + 0.10 \left( \frac{300 \text{ psi}}{\text{span psi}} \right)$ or $\pm 0.025 + 0.10 \left( \frac{21 \text{ bar}}{\text{span bar}} \right)$ in % span
Zero Temperature Effect per 28°C (50°F)	<b>In Analog Mode:</b> $\pm 0.1125\%$ of span. For URV below reference point (500 psi), effect equals: $\pm 0.0125 + 0.10 \left( \frac{500 \text{ psi}}{\text{span psi}} \right)$ or $\pm 0.0125 + 0.10 \left( \frac{35 \text{ bar}}{\text{span bar}} \right)$ in % span  <b>In Digital Mode:</b> $\pm 0.10\%$ of span. For URV below reference point (500 psi), effect equals: $\pm 0.10 \left( \frac{500 \text{ psi}}{\text{span psi}} \right)$ or $\pm 0.10 \left( \frac{35 \text{ bar}}{\text{span bar}} \right)$ in % span
Combined Zero and Span Temperature Effect per 28°C (50°F)	<b>In Analog Mode:</b> $\pm 0.175\%$ of span. For URV below reference point (500 psi), effect equals: $\pm 0.075 + 0.10 \left( \frac{500 \text{ psi}}{\text{span psi}} \right)$ or $\pm 0.075 + 0.10 \left( \frac{35 \text{ bar}}{\text{span bar}} \right)$ in % span  <b>In Digital Mode:</b> $\pm 0.15\%$ of span. For URV below reference point (500 psi), effect equals: $\pm 0.05 + 0.10 \left( \frac{500 \text{ psi}}{\text{span psi}} \right)$ or $\pm 0.05 + 0.10 \left( \frac{35 \text{ bar}}{\text{span bar}} \right)$ in % span
Zero Static Pressure Effect per 1000 psi (70 bar)	$\pm 0.075\%$ of span. For URV below reference point (500 psi), effect equals: $\pm 0.0125 + 0.0625 \left( \frac{500 \text{ psi}}{\text{span psi}} \right)$ or $\pm 0.0125 + 0.0625 \left( \frac{35 \text{ bar}}{\text{span bar}} \right)$ in % span
Combined Zero and Span Static Pressure Effect per 1000 psi (70 bar)	$\pm 0.15\%$ of span. For URV below reference point (500 psi), effect equals: $\pm 0.0875 + 0.0625 \left( \frac{500 \text{ psi}}{\text{span psi}} \right)$ or $\pm 0.0875 + 0.0625 \left( \frac{35 \text{ bar}}{\text{span bar}} \right)$ in % span
Stability	$\pm 0.03\%$ of URL per year.

\* Performance specifications are based on reference conditions of 25°C (77°F), zero (0) static pressure, 10 to 55% RH, and 316 Stainless Steel barrier diaphragm.

## Performance Under Rated Conditions - General for all Models

Parameter	Description
Output (two-wire)	Analog 4 to 20 mA or digital communications DE mode. Options available for FOUNDATION Fieldbus and HART protocol.
Supply Voltage Effect	0.005% span per volt.
Damping Time Constant	Adjustable from 0 to 32 seconds digital damping.
CE Conformity (Europe)	89/336/EEC, Electromagnetic Compatibility (EMC) Directive.
Lightning Protection Option (Code "LP")	Leakage Current: 10 microamps max. @ 42.4 VDC, 93°C Impulse Rating: 10/20 μ sec. 5,000 Amps (50 strikes) 10,000 Amps (20 strikes) (rise/decay) 10/1000 μ sec. 250 Amps (1000 strikes) 500 Amps (400 strikes)

## Physical and Approval Bodies

<b>Barrier Diaphragms Material</b> STD125, STD110 STD120, STD130 STD170	316L SS 316L SS, Hastelloy C-276, Monel, Tantalum 316L SS, Hastelloy C-276
<b>Process Head Material</b> STD125, STD110 STD120, STD130 STD170	316 SS, Carbon Steel (Zinc-plated) 316 SS, Carbon Steel (Zinc-plated), Monel, Hastelloy C-276 316 SS, Carbon Steel (Zinc-plated), Hastelloy C-276
<b>Head Gaskets</b>	Glass filled PTFE standard. Viton and Graphite are optional. See MSG.
<b>Meter Body Bolting</b>	Carbon Steel (Zinc plated) standard. Options include 316 SS, NACE A286 SS bolts and 304 SS nuts and B7M.
<b>Optional Adapter Flange and Bolts</b>	Adapter Flange materials include 316 SS, Hastelloy 276 and Monel. Bolt material for flanges is dependent on process head bolts material chosen. Standard adaptor o-ring material is glass filled PTFE. Viton and graphite are optional.
<b>Mounting Bracket</b>	Carbon Steel (Zinc-plated) or Stainless Steel angle bracket or Carbon Steel flat bracket available (standard options).
<b>Fill Fluid</b>	Silicone DC 200 oil or CTFE (Chlorotrifluoroethylene). Note that Model STD110 is only available with silicone fill fluid.
<b>Electronic Housing</b>	Epoxy-Polyester hybrid paint. Low Copper-Aluminum. Meets NEMA 4X (watertight) and NEMA 7 (explosion proof). Stainless steel optional.
<b>Process Connections</b>	1/4-inch NPT; 1/2-inch NPT with adapter (standard option, meets DIN requirements)
<b>Wiring</b>	Accepts up to 16 AWG (1.5 mm diameter).
<b>Mounting</b>	Can be mounted in virtually any position using the standard mounting bracket. Bracket is designed to mount on 2-inch (50 mm) vertical or horizontal pipe. See Figure 3.
<b>Dimensions</b>	See Figures 4.
<b>Net Weight</b>	9.0 pounds (4.1 Kg).
<b>Approval Bodies</b> - <b>Hazardous Areas</b>  - <b>Canadian Registration Number (CRN)</b>	Approved as explosion proof and intrinsically safe for use in Class I, Division 1, Groups A, B, C, D locations, and nonincendive for Class I, Division 2, Groups A, B, C, D locations. Approved EEx ia IIC T4, T5, T6 and EEx d IIC T5, T6 per ATEX standards. See attached Model Selection Guide for options.  - All ST 3000 model designs, except STG19L, STG99L, STG170, STG180, have been registered in all provinces and territories in Canada and are marked CRN: 0F8914.5C.

**Pressure Equipment Directive  
(97/23/EC)**

The ST 3000 pressure transmitters listed in this Specification have no pressurized internal volume or have a pressurized internal volume rated less than 1,000 bar (14,500 psig) and/or have a maximum volume of less than 0.1 liter. Therefore, these transmitters are either; not subject to the essential requirements of the directive 97/23/EC (PED, Annex 1) and shall not have the CE mark, or the manufacturer has the free choice of a module when the CE mark is required for pressures > 200 bar (2,900 psig).

**NOTE:** Pressure transmitters that are part of safety equipment for the protection of piping (systems) or vessel(s) from exceeding allowable pressure limits, (equipment with safety functions in accordance with Pressure Equipment Directive 97/23/EC article 1, 2.1.3), require separate examination.

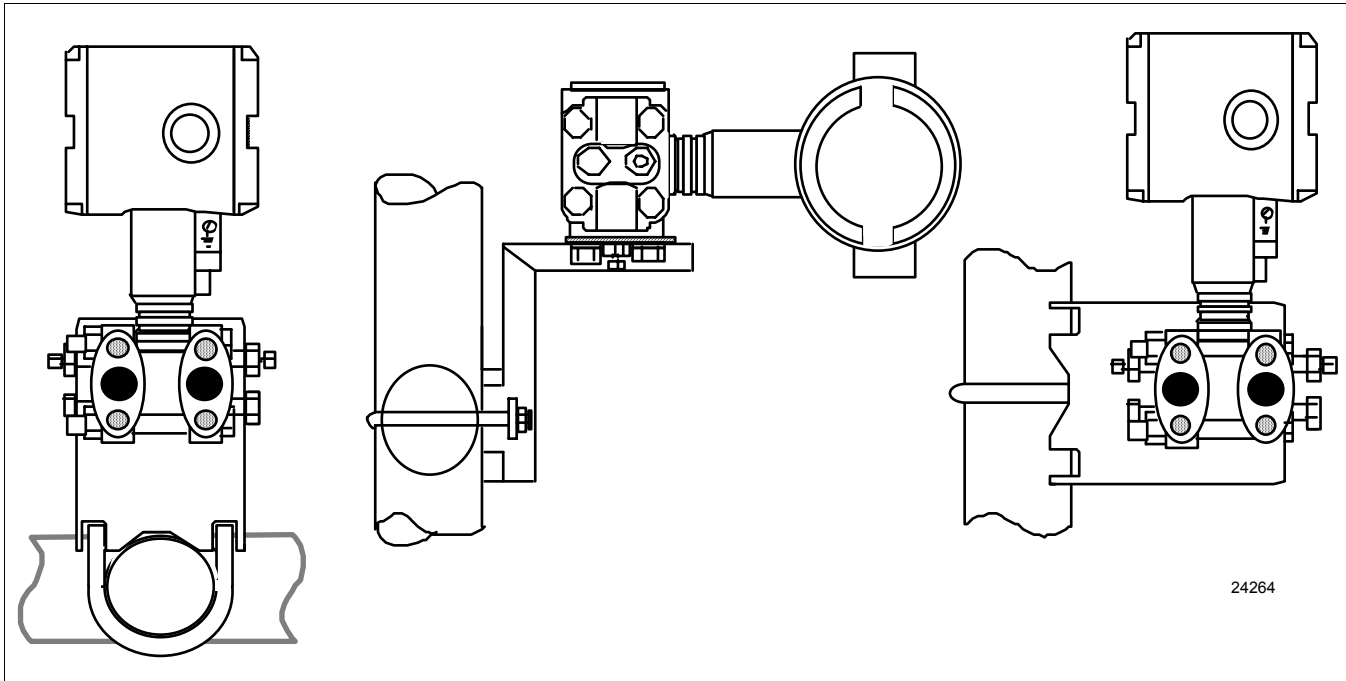

**Figure 3 - Examples of typical mounting positions**

Reference Dimensions:  $\frac{\text{millimeters}}{\text{inches}}$

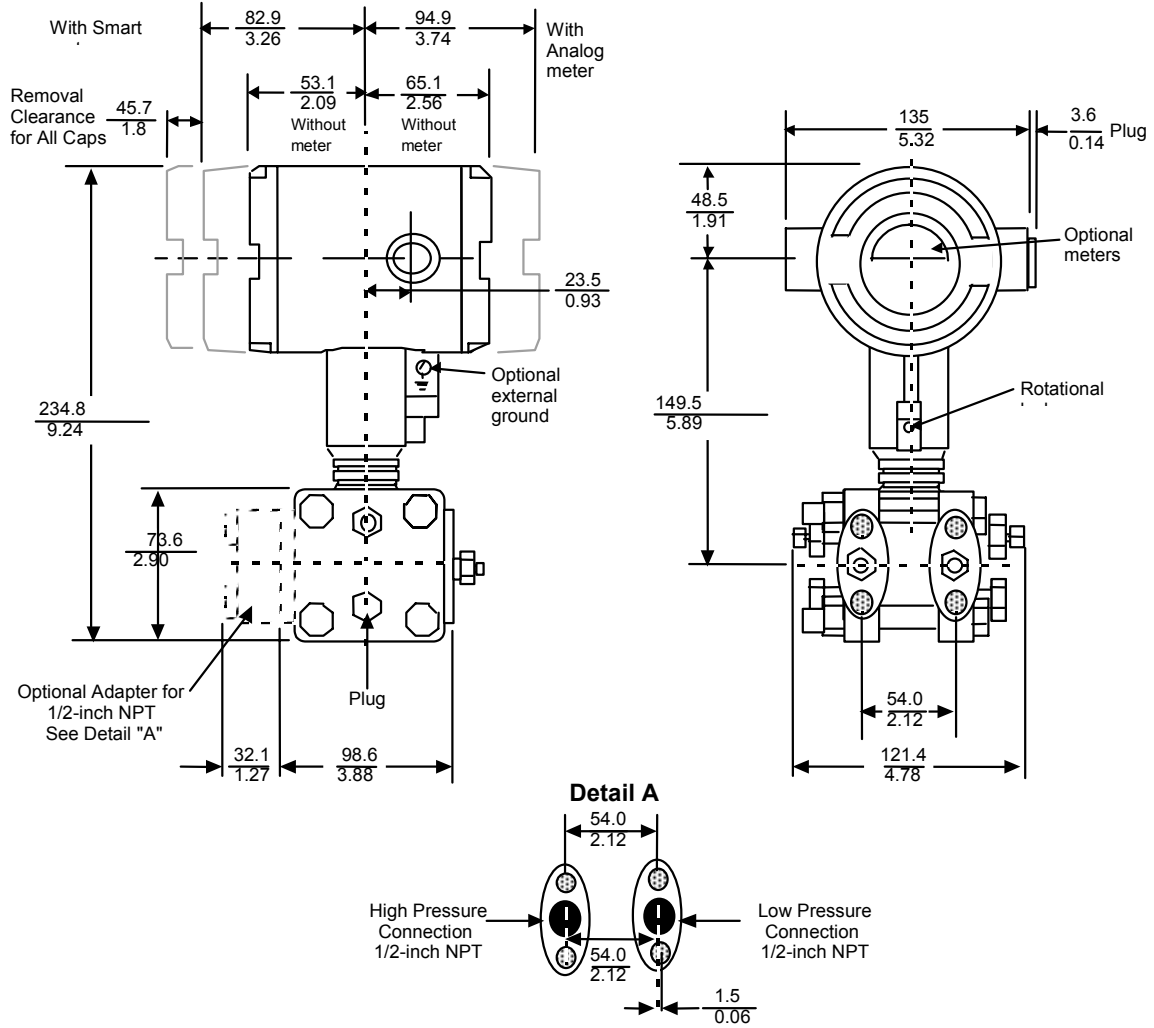

24265

Figure 4 - Typical mounting dimensions of STD110, STD120, STD125, STD130 & STD170 for reference

Options	Ordering Information
<p><b>Mounting Bracket</b> The angle mounting bracket is available in either zinc-plated carbon steel or stainless steel and is suitable for horizontal or vertical mounting on a two inch (50 millimeter) pipe, as well as wall mounting. An optional flat mounting bracket is also available in carbon steel for two inch (50 millimeter) pipe mounting.</p>	<p>Contact your nearest Honeywell sales office, or</p>
<p><b>Indicating Meter (ME and SM Options)</b> Two integral meter options are available. An analog meter (option ME) is available with a dual 0 to 10 square root and 0 to 100% linear scale. The Smart Meter (option SM) provides an LCD display for both analog and digital output and can be configured to display pressure in selected engineering units.</p>	<p>In the U.S.: Honeywell Industrial Automation &amp; Control 16404 North Black Canyon Hwy. Phoenix, AZ 85053 1-800-288-7491</p>
<p><b>HART Protocol Compatibility (Option HC)</b> An optional electronics module is available for the ST 3000 that provides HART Protocol compatibility. Transmitters with the HART Option are compatible with the AMS System. (Contact your AMS Supplier if an upgrade is required.)</p>	<p>In Canada: The Honeywell Centre 155 Gordon Baker Rd. North York, Ontario M2H 3N7 1-800-461-0013</p>
<p><b>Lightning Protection (Option LP)</b> A terminal block is available with circuitry that protects the transmitter from transient surges induced by nearby lightning strikes.</p>	<p>In Latin America: Honeywell Inc. 480 Sawgrass Corporate Parkway, Suite 200 Sunrise, FL 33325 (954) 845-2600</p>
<p><b>Lifetime Warranty (Option WL)</b> Extends limited 1-year warranty policy to 15 years for ST 3000 S100 pressure transmitters. See Honeywell Terms and Conditions.</p>	<p>In Europe and Africa: Honeywell S. A. Avenue du Bourget 1 1140 Brussels, Belgium</p>
<p><i>Specifications are subject to change without notice.</i></p>	<p>In Eastern Europe: Honeywell Praha, s.r.o. Budejovicka 1 140 21 Prague 4, Czech Republic</p>
<p><b>Indicator Configuration (Option CI)</b> Provides custom configuration of Smart Meters</p>	<p>In the Middle East: Honeywell Middle East Ltd. Khalifa Street, Sheikh Faisal Building Abu Dhabi, U. A. E.</p>
<p><b>Tagging (Option TG)</b> Up to 30 characters can be added on the stainless steel nameplate mounted on the transmitter's electronics housing at no extra cost. Note that a separate nameplate on the meter body contains the serial number and body-related data. A stainless steel wired on tag with additional data of up to 4 lines of 28 characters is also available. The number of characters for tagging includes spaces.</p>	<p>In Asia: Honeywell Asia Pacific Inc. Honeywell Building, 17 Changi Business Park Central 1 Singapore 486073 Republic of Singapore</p>
<p><b>Transmitter Configuration (Option TC)</b> The factory can configure the transmitter linear/square root extraction, damping time, LRV, URV and mode (analog/digital) and enter an ID tag of up to eight characters and scratchpad information as specified.</p>	<p>In the Pacific: Honeywell Pty Ltd. 5 Thomas Holt Drive North Ryde NSW Australia 2113 (61 2) 9353 7000</p>
<p><b>Custom Calibration and ID in Memory (Option CC)</b> The factory can calibrate any range within the scope of the transmitter's range and enter an ID tag of up to eight characters in the transmitter's memory.</p>	<p>In Japan: Honeywell K.K. 14-6 Shibaura 1-chrome Minato-ku, Tokyo, Japan 105-0023</p>
<p><b>FOUNDATION Fieldbus (Option FF)</b> Equips transmitter with FF protocol for use in 31.25 kbit/s FF networks. See document 34-ST-03-72 for additional information on ST 3000 Fieldbus transmitters.</p>	<p>Or, visit Honeywell on the World Wide Web at: <a href="http://www.honeywell.com">http://www.honeywell.com</a></p>
<p><b>High Accuracy (Option HA)</b> Extends applicable S100 models to +/- 0.0375% analog reference accuracy</p>	

## Model Selection Guide (34-ST-16-01)

### Instructions

- Select the desired Key Number. The arrow to the right marks the selection available.
- Make one selection from each Table I and II using the column below the proper arrow.
- Select as many Table III options as desired (if no options or approvals are desired, specify 9X).  
A (♦) denotes unrestricted availability. A letter denotes restricted availability.

Restrictions follow Table IV.

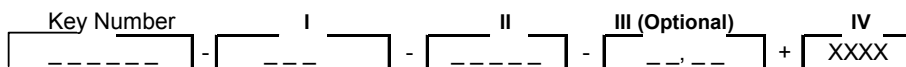

KEY NUMBER	Selection	Availability				
<b>Span</b>						
0-1" to 0-400" H <sub>2</sub> O/0-2.5 to 0-1000 mbar Body Rating: 4500 psi (315 bar)	STD120	↓				
0-5 to 0-100 psi/0-0.35 to 0-7 bar Body Rating: 4500 psi (315 bar)	STD130		↓			
0-100 to 0-3000 psi/0-7 to 0-210 bar Body Rating: 4500 psi (315 bar)	STD170			↓		
0-25" to 0-600" H <sub>2</sub> O/0-62.2 to 0-1500 mbar Body Rating: 4500 psi (315 bar)	STD125				↓	
0-0.4" to 0-10" H <sub>2</sub> O/0-1 to 0-25 mbar Body Rating: 50 psi (3.5 bar) Compound Characterized	STD110					↓

**TABLE I - METER BODY**

	Wetted Process Heads	Vent/Drain Valves ** and Plugs	Barrier Diaphragms					
Material of Construction	Carbon Steel *	316 St. St.	316 LSS	A __	♦	♦	♦	♦
	Carbon Steel *	316 St. St.	Hastelloy C	B __	♦	♦	♦	♦
	Carbon Steel *	316 St. St.	Monel	C __	♦	♦		
	Carbon Steel *	316 St. St.	Tantalum	D __	♦	♦		
	316 St. St.	316 St. St.	316 LSS	E __	♦	♦	♦	♦
	316 St. St.	316 St. St.	Hastelloy C	F __	♦	♦	♦	
	316 St. St.	316 St. St.	Monel	G __	♦	♦		
	316 St. St.	316 St. St.	Tantalum	H __	♦	♦		
	Hastelloy C	Hastelloy C	Hastelloy C	J __	♦	♦	♦	
	Hastelloy C	Hastelloy C	Tantalum	K __	♦	♦		
Monel	Monel	Monel	L __	♦	♦			
Fill Fluid	Silicone			_ 1 _	♦	♦	♦	♦
	CTFE			_ 2 _	♦	♦	♦	♦
Process Head Configuration	1/4" NPT			_ _ A	♦	♦	♦	♦
	1/2" NPT with Adapter (on 1/4" NPT Head)			_ _ H	t	t	t	t

\* Carbon Steel heads are zinc-plated.

\*\* Vent/Drains are Teflon coated for lubricity.

Model Selection Guide, cont.

TABLE II	Selection	Availability				
		20	30	70	25	10
No Selection	00000	*	*	*	*	*
<b>TABLE III - OPTIONS</b>						
None	00	*	*	*	*	*
<b>Communication Options</b>						
FOUNDATION Fieldbus Communications	FF	r	r	r	r	r
HART Protocol compatible electronics	HC	y	y	y	y	y
<b>Indicating Meter Options</b>						
Analog Meter (0-100 Even 0-10 Square Root)	ME	*	*	*	*	*
Smart Meter	SM	*	*	*	*	*
Customer Configuration of Smart Meter	CI	e	e	e	e	e
Local Zero & Span	ZS	m	m	m	m	m
Local Zero	LZ	x	x	x	x	x
<b>Transmitter Housing &amp; Electronics Options</b>						
Lightning Protection	LP	*	*	*	*	*
Custom Calibration and I.D. in Memory	CC	*	*	*	*	*
Transmitter Configuration - non-Fieldbus	TC	*	*	*	*	*
Write Protection	WP	*	*	*	*	*
316 ST.ST. Electronics Housing - with M20 Conduit Connections	SH	n	n	n	n	n
1/2" NPT to M20 316SS Conduit Adapter (BASEEFA EEx d IIC)	A1	n	n	n	n	n
1/2" NPT to 3/4" NPT 316 SS Conduit Adapter	A2	i	i	i	i	i
Stainless Steel Housing with M20 to 1/2" NPT 316 SS Conduit Adapter (use for FM and CSA Approvals)	A3	i	i	i	i	i
Stainless Steel Customer Wired-On Tag (4 lines, 28 characters per line, customer supplied information)	TG	*	*	*	*	*
Stainless Steel Customer Wired-On Tag (blank)	TB	*	*	*	*	*
High Accuracy	HA	*	*	*	*	*
End Cap Live Circuit Warning Label in Spanish (only with ATEX 3D)	SP	a	a	a	a	a
End Cap Live Circuit Warning Label in Portuguese (only with ATEX 3D)	PG	a	a	a	a	a
End Cap Live Circuit Warning Label in Italian (only with ATEX 3D)	TL	a	a	a	a	a
End Cap Live Circuit Warning Label in German (only with ATEX 3D)	GE	a	a	a	a	a
<b>Meter Body Options</b>						
316 SS Bolts and 316 SS Nuts for Process Heads	SS	*	*	*	*	*
B7M Bolts and Nuts for Process Heads	B7	*	*	*	*	*
NACE A286SS Bolts and 304SS Nuts for Process Heads	CR	*	*	*	*	*
316SS Adapter Flange - 1/2" NPT with CS Bolts	S2	c	c	c	c	c
316SS Adapter Flange - 1/2" NPT with 316SS Bolts	S3	c	c	c	c	c
316SS Adapter Flange - 1/2" NPT with NACE A286 Bolts	S4	c	c	c	c	c
316SS Adapter Flange - 1/2" NPT with B7M Bolts	S5	c	c	c	c	c
Hastelloy C Adapter Flange - 1/2" NPT with CS Bolts	T2	c	c	c		
Hastelloy C Adapter Flange - 1/2" NPT with 316SS Bolts	T3	c	c	c		
Monel Adapter Flange - 1/2" NPT with CS Bolts	V2	c	c	c		
Monel Adapter Flange - 1/2" NPT with 316SS Bolts	V3	c	c	c		
316SS Blind Adapter Flange with CS Bolts	B3	*	*	*	*	*
316SS Blind Adapter Flange with 316SS Bolts	B4	*	*	*	*	*
316SS Blind Adapter Flange with NACE A286 Bolts	B5	*	*	*	*	*
316SS Blind Adapter Flange with B7M Bolts	B6	*	*	*	*	*
Side Vent/Drain (End Vent Drain is standard)	SV	*	*	*	*	*
SS Center Vent Drain and Bushing	CV	*	*	*	*	*
Viton Process Head Gaskets (adapter gaskets ordered separately)	VT	*	*	*	*	*
Viton Flange Adaptor Gaskets	VF	*	*	*	*	*
Graphite Process Head & Flange Adaptor Gaskets	GF	*	*	*	*	*

Model Selection Guide, cont.

TABLE III - OPTIONS (continued)	Selection	Availability				
		20	30	70	25	10
<b>Transmitter Mounting Brackets Options</b>						
Mounting Bracket - Carbon Steel	MB	♦	♦	♦	♦	♦
Mounting Bracket - ST. ST.	SB	♦	♦	♦	♦	♦
Flat Mounting Bracket - Carbon Steel	FB	♦	♦	♦	♦	♦
<b>Services/Certificates/Marine Type Approval Options</b>						
Clean Transmitter for Oxygen or Chlorine Service with Certificate	0X	j	j	j		
Over-Pressure Leak Test with F3392 Certificate	TP	♦	♦	♦	♦	♦
Calibration Test Report and Certificate of Conformance (F3399)	F1	♦	♦	♦	♦	♦
Certificate of Conformance (F3391)	F3	♦	♦	♦	♦	♦
Certificate of Origin (F0195)	F5	♦	♦	♦	♦	♦
FMEDA (SIL) Certificate	F6	♦	♦	♦	♦	♦
NACE Certificate (F0198)	F7	o	o	o	o	o
Marine Type Approvals (DNV, ABS, BV & LR)	MT	2	2	2	2	2
<b>Warranty Options</b>						
Additional Warranty - 1 year	W1	♦	♦	♦	♦	♦
Additional Warranty - 2 years	W2	♦	♦	♦	♦	♦
Additional Warranty - 3 years	W3	♦	♦	♦	♦	♦
Additional Warranty - 4 years	W4	♦	♦	♦	♦	♦
Lifetime Warranty - 15 years	WL	♦	♦	♦	♦	♦

TABLE III - OPTIONS (continued)			Selection	Availability				
Certificate	Approval Type	Location or Classification		20	30	70	25	10
No hazardous location approvals			9X	♦	♦	♦	♦	♦
Factory Mutual	Explosion Proof	Class I, Div. 1, Groups A,B,C,D	1C	♦	♦	♦	♦	♦
	Dust Ignition Proof	Class II, III Div. 1, Groups E,F,G		♦	♦	♦	♦	♦
	Non-Incendive	Class I, Div. 2, Groups A,B,C,D		♦	♦	♦	♦	♦
CSA	Intrinsically Safe	Class I, II, III, Div. 1, Groups A,B,C,D,E,F,G	2J	♦	♦	♦	♦	♦
	Explosion Proof	Class I, Div. 1, Groups B,C,D		♦	♦	♦	♦	♦
	Dust Ignition Proof	Class II, III, Div. 1, Groups E,F,G		♦	♦	♦	♦	♦
SA (Australia)	Intrinsically Safe	Ex ia IIC T4	4G	♦	♦	♦	♦	♦
	Non-Sparking	Ex n IIC T6 (T4 with SM option)		♦	♦	♦	♦	♦
ATEX*	Intrinsically Saft, Zone 0/1	⊕II 1 G EEx ia IIC T4, T5,T6	3S	♦	♦	♦	♦	♦
	Flameproof, Zone 1	⊕II 2 G EEx d IIC T5, T6, Enclosure IP 66/67	3D	♦	♦	♦	♦	♦
	Non-Sparking, Zone 2	⊕II 3 G EEx nA, IIC T6 (Honeywell). Enclosure IP 66/67	3N	♦	♦	♦	♦	♦
	Multiple Marking** Int. Safe, Zone 0/1, or Flameproof, Zone 1, or Non-Sparking, Zone 2	Ex II 1 G EEx ia IIC T4, T5, T6 Ex II 2 G EEx d IIC T5, T6 Ex II 3 G EEx nA, IIC T6 (Honeywell) Enclosure IP 66/67	3H	♦	♦	♦	♦	♦
INMETRO (Brazil)	Flameproof, Zone 1	Ex d IIC T5	6D	♦	♦	♦	♦	♦

\* See ATEX installation requirements in the ST 3000 User's Manual

\*\* The user must determine the type of protection required for installation of the equipment. The user shall then check the box [✓] adjacent to the type of protection used on the equipment certification nameplate. Once a type of protection has been checked on the nameplate, subsequently the equipment shall not be reinstalled using any of the other certification types.

## Model Selection Guide, cont.

**TABLE IV**

Factory Identification	XXXX	♦	♦	♦	♦	♦
------------------------	------	---	---	---	---	---

**RESTRICTIONS**

Restriction		Available Only With		Not Available With
Letter	Table	Selection	Table	Selection
a	III	3D or 3H		
b	Select only one option from this group			
c	I	__ H		
e	III	SM		
i	III	1C or 2J		
j	I	_ 2 _		
m			III	ME, FF
n			III	1C, 2J
o	III	CR, S4, B5		
r			III	TC, ME, 4G
t	III	S2,S3,S4,S5,T2,T3,V2,V3		
x	III	FF, SM		
y			III	4G
z			III	FB

**Note:** See ST-83 for Published Specials with pricing.  
 See ST-89 and User's Manual for part numbers.  
 See ST-OE-9 for OMS Order Entry Information including TC, manuals, certificates, drawings and SPINS.  
 See ST-OD-1 for tagging, ID, Transmitter Configuration (TC) and calibration including factory default values.

ST 3000® is a registered trademark of Honeywell International Inc.

HART\* is a trademark of the Hart Communication Foundation.

FOUNDATION™ is a trademark of the Fieldbus Foundation.



**Honeywell Process Solutions**

Honeywell International Inc.  
 2500 W. Union Hill Drive  
 Phoenix, Arizona 85027