

ST 3000 Smart Transmitter Series 100 Absolute Pressure Models

34-ST-03-61
10/99

Specification and Model Selection Guide

STA122	0 to 780 mmHgA	0 to 1,040 mbarA
STA140	0 to 500 psia	0 to 35 barA

Function

Honeywell's ST 3000[®] Series 100 Absolute Pressure Transmitters bring proven "smart" technology to a wide spectrum of absolute pressure measurement applications with varying process interface requirements. They transmit an output signal proportional to the measured variable in either an analog 4 to 20 milliamper format or in a digital DE protocol format for direct digital integration with our TDC 3000^{®X} control system. Additional protocol options available for the ST 3000 Series 100 transmitters include FOUNDATION[™] Fieldbus¹ and HART[®]². See the Model Selection Guide for help in selecting the correct ordering code for the desired protocol.

You easily select the analog or digital transmission format through the Smart Field Communicator (SFC[®]) which is the common hand-held operator interface for our Smartline[®] Transmitters. All configuration, operation, and communications functions are under the control of the ST 3000 Smart Transmitter's micro-processor and are accessible through the SFC.

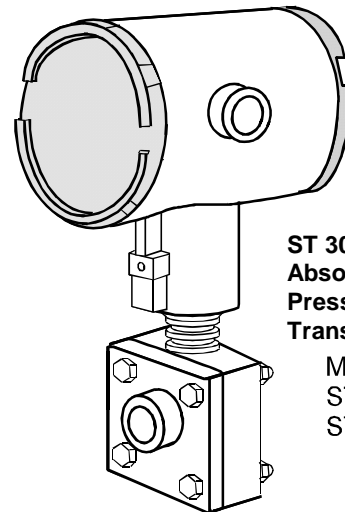

**ST 3000
Absolute
Pressure
Transmitter**
Models:
STA122
STA140

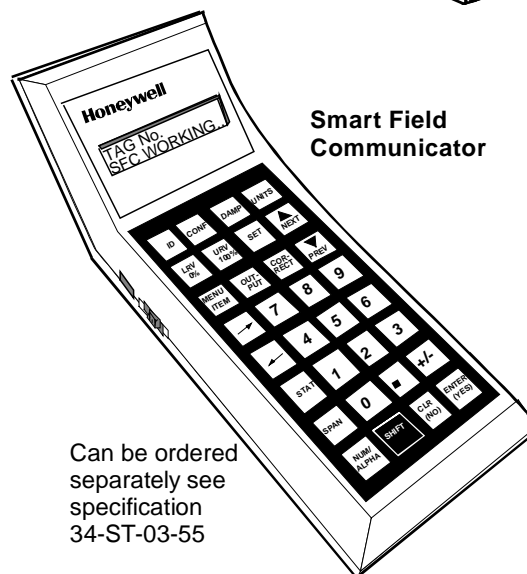

**Smart Field
Communicator**

Can be ordered
separately see
specification
34-ST-03-55

24802

¹ FOUNDATION[™] Fieldbus is a trademark of the Fieldbus Foundation.

² HART is a registered trademark of the Hart Communication Foundation.

Figure 1—Series 100 Absolute Pressure Transmitters feature proven "smart" technology and come in two models to meet varying application needs.

Features	Description	
<ul style="list-style-type: none"> • Only need two models to cover wide range of pressure measurements. • Direct digital integration with TDC 3000^X system provides local measurement accuracy to the system level without adding typical A/D and D/A converter inaccuracies • Unique piezoresistive sensor automatically compensates input for temperature. • Added “smart” features include configuring lower and upper range values, simulating accurate analog output, and selecting preprogrammed engineering units for display. • Smart transmitter personality with local or remote interfacing means significant manpower efficiency improvements in commissioning, start-up, and ongoing maintenance functions. 	<p>The ST 3000 transmitter can replace any 4 to 20 milliampere output transmitter in use today, and operates over a standard two-wire system.</p> <p>The measuring means is a piezoresistive sensor which actually contains a pressure sensor and a temperature sensor. Microprocessor-based electronics provide higher span-turndown ratio, improved temperature compensation, and improved accuracy.</p> <p>Like other Smartline Transmitters, the ST 3000 features two-way communication between the operator and the transmitter through our SFC.</p>	<p>You can connect the SFC anywhere that you can access the transmitter signal lines, and it provides the capabilities of transmitter adjustments and diagnostics from remote locations, such as the control room.</p> <p>The transmitter's meter body and electronics housing resist shock, vibration, corrosion, and moisture. The electronics housing contains a compartment for the single-board electronics, which is isolated from an integral junction box. The single-board electronics is replaceable and interchangeable with any other ST 3000 Series 100 and Series 900 model transmitter.</p>

Specifications

Operating Conditions – All Models

Parameter	Reference Condition		Rated Condition		Operative Limits		Transportation and Storage	
	°C	°F	°C	°F	°C	°F	°C	°F
Ambient Temperature	25±1	77±2	-40 to 85	-40 to 185	-40 to 93	-40 to 200	-55 to 125	-67 to 257
Meter Body Temperature								
STA122	25±1	77±2	See Figure 2		See Figure 2		-55 to 125	-67 to 257
STA140	25±1	77±2	-40 to 80	-40 to 176	-40 to 80	-40 to 176	-55 to 125	-67 to 257
Humidity %RH	10 to 55		0 to 100		0 to 100		0 to 100	
Overpressure								
STA122 mmHgA mbarA	0 0		Full vacuum to 1550 Full vacuum to 2066		Full vacuum to 1550 Full vacuum to 2066			
STA140 psia barA	0 0		750 52		750 52			
Vacuum Region - Minimum Pressure								
STA122 STA140	See Figure 2. Operate within specifications above 25 mmHgA (33 mbarA). Short term exposure (2 hours at 70°C/158°F) to full vacuum will not result in damage.							
Supply Voltage, Current, and Load Resistance	Voltage Range: 10.8 to 42.4 Vdc at terminals Current Range: 3.0 to 21.8 mA Load Resistance: 0 to 1440 ohms (as shown in Figure 3)							

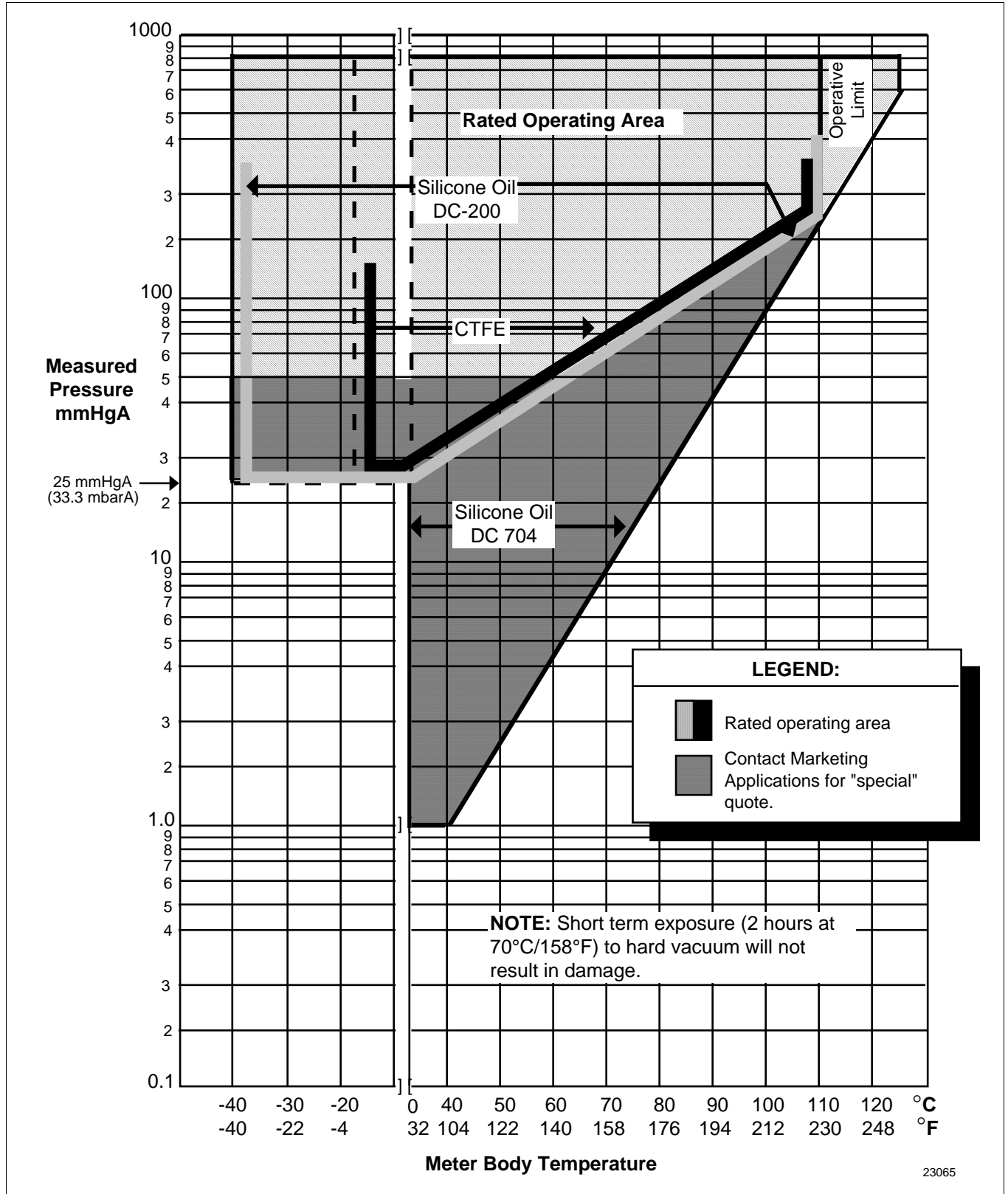

Figure 2 - Measured pressure versus meter body temperature chart for model STA122.

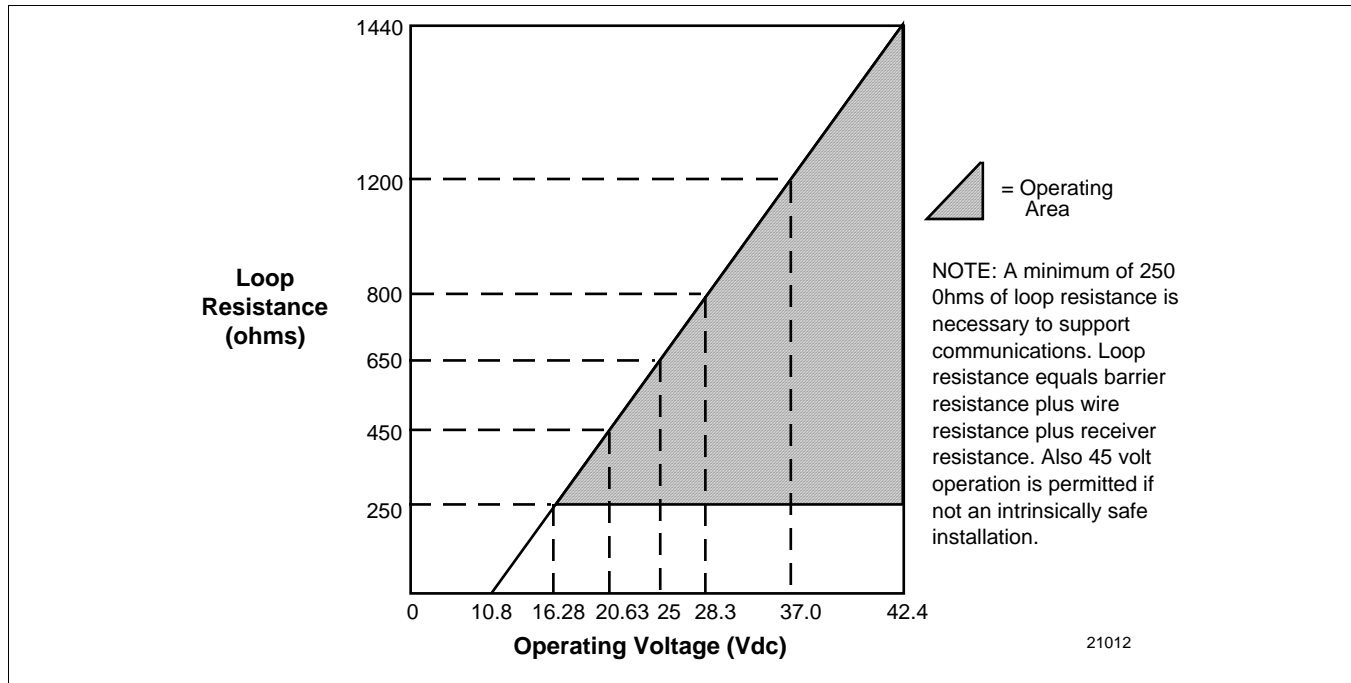

Figure 3 - Supply voltage and loop resistance chart.

Performance Under Rated Conditions* - Model STA122 (0 to 780 mmHgA)

Parameter		Description
Upper Range Limit	mmHgA mbarA	780 (0°C/32°F is standard reference temperature for mmHg range.) 1040
Minimum Span	mmHgA mbarA	50 67
Turndown Ratio		15 to 1
Zero Suppression		No limit except minimum span within 0 (absolute zero) to +100% URL.
Accuracy (Reference – Includes combined effects of linearity, hysteresis, and repeatability) <ul style="list-style-type: none"> Accuracy includes residual error after averaging successive readings. For FOUNDATION Fieldbus use Digital Mode specifications. For HART use Analog Mode specifications. 		<p>In Analog Mode: ±0.075% of calibrated span or upper range value (URV), whichever is greater, terminal based.</p> <p>For URV below reference point (90 mmHgA), accuracy equals: $\pm 0.025 + 0.05 \left(\frac{90 \text{ mmHgA}}{\text{span mmHgA}} \right)$ or $\pm 0.025 + 0.05 \left(\frac{120 \text{ mbarA}}{\text{span mbarA}} \right)$ in % span</p> <p>In Digital Mode: ±0.0625% of calibrated span or upper range value (URV), whichever is greater, terminal based.</p> <p>For URV below reference point (90 mmHgA), accuracy equals: $\pm 0.0125 + 0.05 \left(\frac{90 \text{ mmHgA}}{\text{span mmHgA}} \right)$ or $\pm 0.0125 + 0.05 \left(\frac{120 \text{ mbarA}}{\text{span mbarA}} \right)$ in % span</p>
Zero Temperature Effect per 28°C (50°F)		<p>In Analog Mode: ±0.0875% of calibrated span.</p> <p>For URV below reference point (180 mmHgA), effect equals: $\pm 0.0125 + 0.075 \left(\frac{180 \text{ mmHgA}}{\text{span mmHgA}} \right)$ or $\pm 0.0125 + 0.075 \left(\frac{240 \text{ mbarA}}{\text{span mbarA}} \right)$ in % span</p> <p>In Digital Mode: ±0.075% of calibrated span.</p> <p>For URV below reference point (180 mmHgA), effect equals: $\pm 0.075 \left(\frac{180 \text{ mmHgA}}{\text{span mmHgA}} \right)$ or $\pm 0.075 \left(\frac{240 \text{ mbarA}}{\text{span mbarA}} \right)$ in % span</p>

* Performance specifications are based on reference conditions of 25°C (77°F), 10 to 55% RH, and 316L Stainless Steel barrier diaphragm.

Performance Under Rated Conditions - Model STA122 (0 to 780 mmHgA), Continued

Parameter	Description
Combined Zero and Span Temperature Effect per 28°C (50°F)	<p>In Analog Mode: ±0.175% of calibrated span. For URV below reference point (180 mmHgA), effect equals: $\pm 0.1 + 0.075 \left(\frac{180 \text{ mmHgA}}{\text{span mmHgA}} \right)$ or $\pm 0.1 + 0.075 \left(\frac{240 \text{ mbarA}}{\text{span mbarA}} \right)$ in % span</p> <p>In Digital Mode: ±0.15% of calibrated span. For URV below reference point (180 mmHgA), effect equals: $\pm 0.075 + 0.075 \left(\frac{180 \text{ mmHgA}}{\text{span mmHgA}} \right)$ or $\pm 0.075 + 0.075 \left(\frac{240 \text{ mbarA}}{\text{span mbarA}} \right)$ in % span</p>

Performance Under Rated Conditions* - Model STA140 (0 to 500 psia)

Parameter	Description
Upper Range Limit psia barA	500 35
Minimum Span psia barA	5 0.35
Turndown Ratio	100 to 1
Zero Suppression	No limit except minimum span within 0 (absolute zero) to +100% URL.
<p>Accuracy (Reference – Includes combined effects of linearity, hysteresis, and repeatability)</p> <ul style="list-style-type: none"> Accuracy includes residual error after averaging successive readings. For FOUNDATION Fieldbus use Digital Mode specifications. For HART use Analog Mode specifications. 	<p>In Analog Mode: ±0.075% of calibrated span or upper range value (URV), whichever is greater, terminal based. For URV calibrated below reference point (20 psia), accuracy equals: $\pm 0.025 + 0.05 \left(\frac{20 \text{ psia}}{\text{span psia}} \right)$ or $\pm 0.025 + 0.05 \left(\frac{1.4 \text{ barA}}{\text{span barA}} \right)$ in % span</p> <p>In Digital Mode: ±0.0625% of calibrated span or upper range value (URV), whichever is greater, terminal based. For URV calibrated below reference point (20 psia), accuracy equals: $\pm 0.0125 + 0.05 \left(\frac{20 \text{ psia}}{\text{span psia}} \right)$ or $\pm 0.0125 + 0.05 \left(\frac{1.4 \text{ barA}}{\text{span barA}} \right)$ in % span</p>
Zero Temperature Effect per 28°C (50°F)	<p>In Analog Mode: ±0.0625% of calibrated span. For URV below reference point (50 psia), effect equals: $\pm 0.0125 + 0.05 \left(\frac{50 \text{ psia}}{\text{span psia}} \right)$ or $\pm 0.0125 + 0.05 \left(\frac{3.5 \text{ barA}}{\text{span barA}} \right)$ in % span</p> <p>In Digital Mode: ±0.05% of calibrated span. For URV below reference point (50 psia), effect equals: $\pm 0.05 \left(\frac{50 \text{ psia}}{\text{span psia}} \right)$ or $\pm 0.05 \left(\frac{3.5 \text{ barA}}{\text{span barA}} \right)$ in % span</p>
Combined Zero and Span Temperature Effect per 28°C (50°F)	<p>In Analog Mode: ±0.10% of calibrated span. For URV below reference point (50 psia), effect equals: $\pm 0.05 + 0.05 \left(\frac{50 \text{ psia}}{\text{span psia}} \right)$ or $\pm 0.05 + 0.05 \left(\frac{3.5 \text{ barA}}{\text{span barA}} \right)$ in % span</p> <p>In Digital Mode: ±0.075% of calibrated span. For URV below reference point (50 psia), effect equals: $\pm 0.025 + 0.05 \left(\frac{50 \text{ psia}}{\text{span psia}} \right)$ or $\pm 0.025 + 0.05 \left(\frac{3.5 \text{ barA}}{\text{span barA}} \right)$ in % span</p>

* Performance specifications are based on reference conditions of 25°C (77°F), 10 to 55% RH, and 316L Stainless Steel barrier diaphragm.

Performance Under Rated Conditions - General for all Models

Parameter	Description
Output (two-wire)	Analog 4 to 20 mA or digital communications DE mode. Options available for FOUNDATION Fieldbus and HART protocol.
Supply Voltage Effect	0.005% span per volt.
Damping Time Constant	Adjustable from 0 to 32 seconds digital damping.
CE Conformity (Europe)	89/336/EEC, Electromagnetic Compatibility (EMC) Directive.
Lightning Protection Option (Code "LP")	Leakage Current: 10 microamps max. @ 42.4 VDC, 93°C Impulse Rating: 10/20 μ sec. 5,000 Amps (50 strikes) 10,000 Amps (20 strikes) (rise/decay) 10/1000 μ sec. 250 Amps (1000 strikes) 500 Amps (400 strikes)

Physical and Approval Bodies

Parameter	Description
Barrier Diaphragm Material	316L SS, Hastelloy C-276, Monel
Process Head Material	316 SS, Carbon Steel (Zinc-plated), Monel, Hastelloy C-276
Head Gaskets	Viton is standard. Teflon is optional but not recommended for leak-proof service under full vacuum.
Meter Body Bolting	Carbon Steel (Zinc plated, standard) or A286 SS (NACE) bolts and 302/304 SS (NACE) nuts for heads.
Mounting Bracket	Carbon Steel (Zinc-plated) or Stainless Steel angle bracket or Carbon Steel flat bracket available.
Fill Fluid	Silicone DC 200 oil or CTFE (Chlorotrifluoroethylene) Note that DC 704 is available – Please contact Product Marketing.
Electronic Housing	Epoxy-Polyester hybrid paint. Low Copper-Aluminum. Meets NEMA 4X (watertight) and NEMA 7 (explosion proof). Stainless steel optional.
Process Connections	1/2-inch NPT, 9/16-18 Aminco, DIN.
Wiring	Accepts up to 16 AWG (1.5 mm diameter).
Mounting	Can be mounted in virtually any position using the standard mounting bracket. Bracket is designed to mount on 2-inch (50 mm) vertical or horizontal pipe. See Figure 4.
Dimensions	See Figure 5
Net Weight	10 pounds (4.5 Kg)
Approval Bodies	Approved as explosion proof and intrinsically safe for use in Class I, Division 1, Groups A, B, C, D locations, and nonincendive for Class I, Division 2 Groups A, B, C, D locations. Approved EEx ia IIC T5 and EEx d IIC T6 per CENELEC standards; and Ex N II T5 per BS 6941.

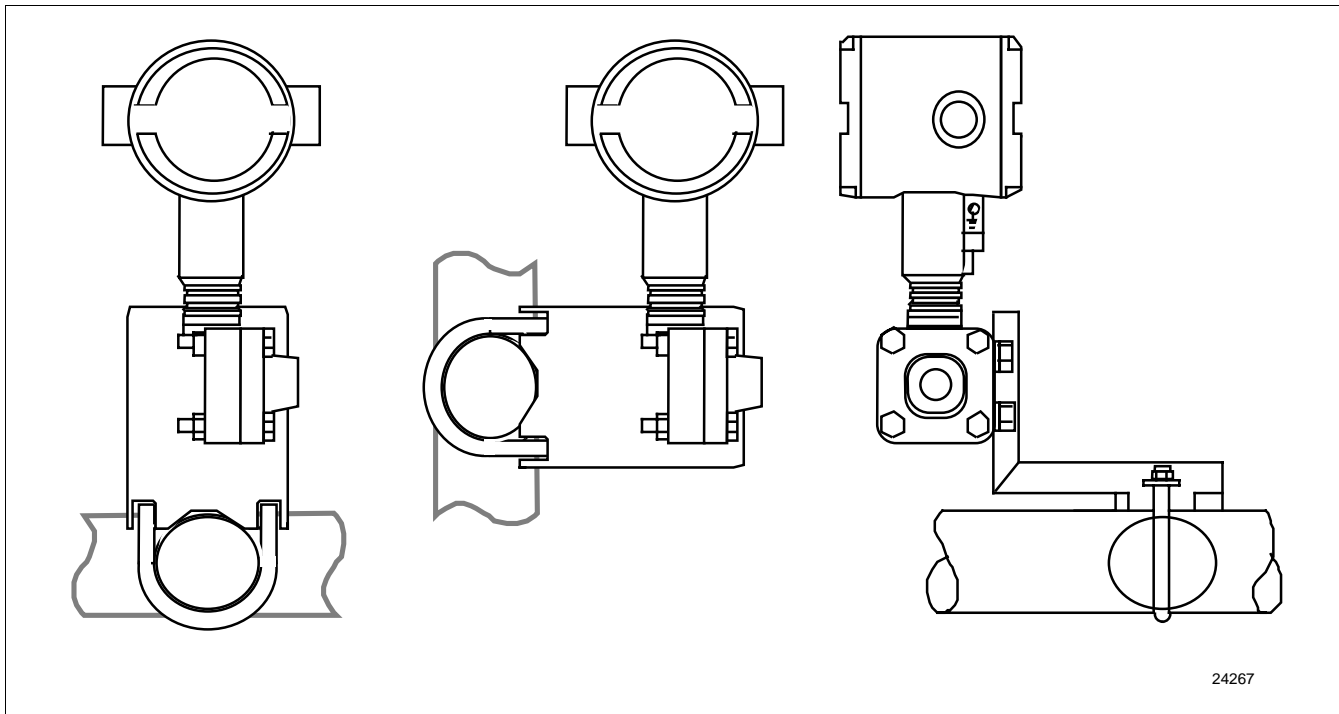
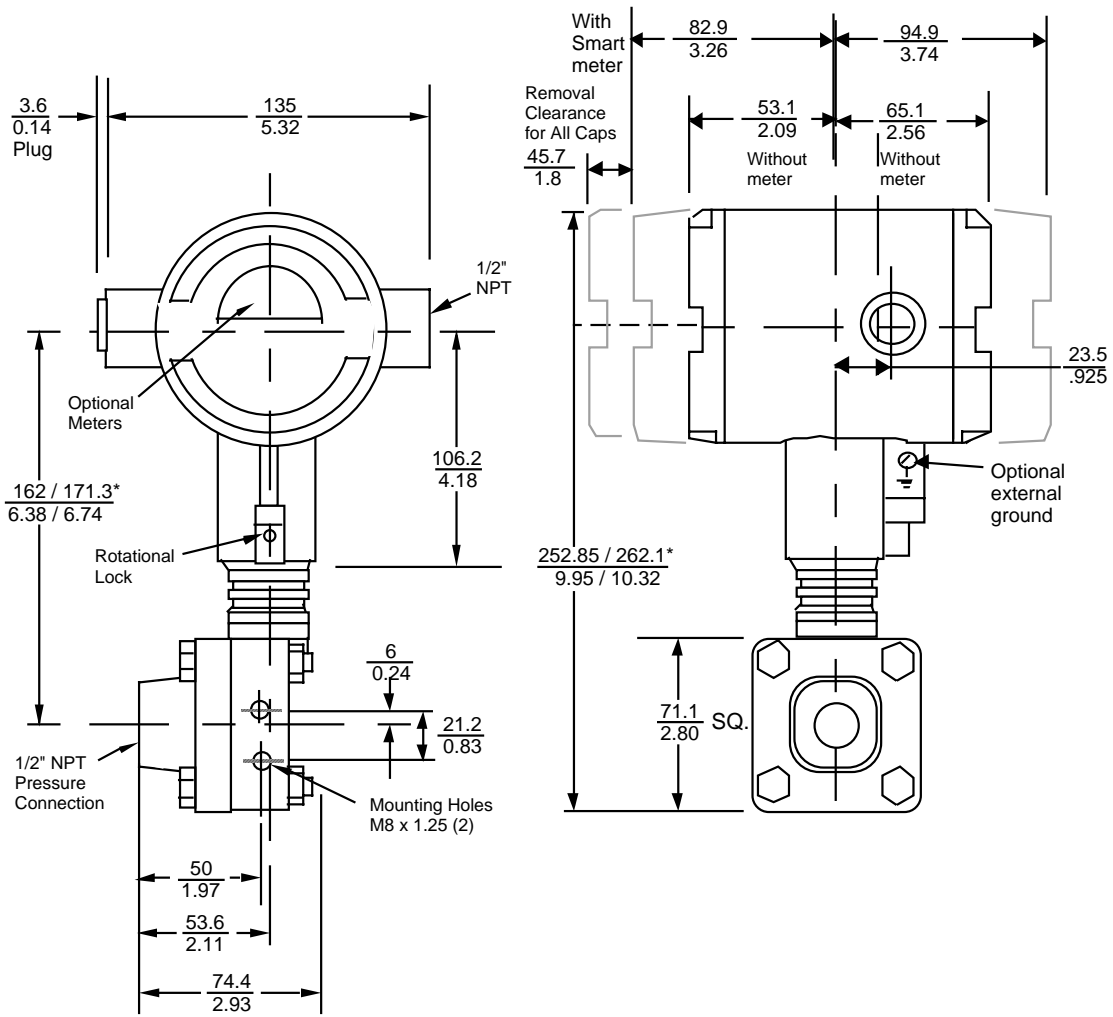

Figure 4 - Examples of typical mounting positions for single-head models STA122 and STA140.

Reference Dimensions: $\frac{\text{millimeters}}{\text{inches}}$



* Dimensions vary due to slight differences in electronics housing designs

24803

Figure 5 - Typical mounting dimensions for single-head models for reference.

Options

Mounting Bracket

The angle mounting bracket is available in either zinc-plated carbon steel or stainless steel and is suitable for horizontal or vertical mounting on a two inch (50 millimeter) pipe, as well as wall mounting. An optional flat mounting bracket is also available in carbon steel for two inch (50 millimeter) pipe mounting.

Indicating Meter

Two integral meter options are available. An analog meter (option ME) is available with a 0 to 100% linear scale. The Smart Meter (option SM) provides an LCD display for both analog and digital output and can be configured to display pressure in pre-selected engineering units.

HART Protocol Compatibility (Option HC)

An optional electronics module is available for the Series 100 that provides HART Protocol compatibility. Transmitters with the HART Option are compatible with the AMS System. (Contact your AMS Supplier if an upgrade is required.)

Lightning Protection

A terminal block is available with circuitry that protects the transmitter from transient surges induced by nearby lightning strikes.

Tagging (Option TG)

Up to 30 characters can be added on the stainless steel nameplate mounted on the transmitter's electronics housing at no extra cost. Note that a separate nameplate on the meter body contains the serial number and body-related data. A stainless steel wired on tag with additional data of up to 4 lines of 28 characters is also available. The number of characters for tagging includes spaces.

Transmitter Configuration (Option TC)

The factory can configure the transmitter linear/square root extraction, damping time, LRV, URV and mode (analog/digital) and enter an ID tag of up to eight characters and scratchpad information as specified.

Custom Calibration and ID in Memory (Option CC)

The factory can calibrate any range within the scope of the transmitter's range and enter an ID tag of up to eight characters in the transmitter's memory.

FOUNDATION Fieldbus (Option FF)

Equips transmitter with FF protocol for use in 31.25 kbit/s FF networks. See document 34-ST-03-72 for additional information on ST 3000 Fieldbus transmitters.

Ordering Information

Contact your nearest Honeywell sales office, or

In the U.S.:
Honeywell
Industrial Automation & Control
16404 N. Black Canyon Highway
Phoenix, AZ 85023
1-800-288-7491

In Canada:

The Honeywell Centre
155 Gordon Baker Rd.
North York, Ontario
M2H 3N7
1-800-461-0013

In Latin America:

Honeywell Inc.
480 Sawgrass Corporate Parkway,
Suite 200
Sunrise, FL 33325
(954) 845-2600

In Europe:

Honeywell PACE
1, Avenue du Bourget
B-1140 Brussels, Belgium
[32-2] 728-2111

In Asia:

Honeywell Asia Pacific Inc.
Room 3213-25
Sun Hung Kai Centre
No. 30 Harbour Road
Wanchai, Hong Kong
2829-8298

In the Pacific:

Honeywell Limited
5 Thomas Holt Drive
North Ryde NSW 2113
Australia
(61 2) 9353 7000

Or, visit Honeywell on the World
Wide Web at:

<http://www.honeywell.com>

Specifications are subject to change without notice.

Model Selection Guide

Instructions

- Select the desired Key Number. The arrow to the right marks the selection available.
- Make one selection from each Table I and II using the column below the proper arrow.
- Select as many Table III options as desired (if no options are desired, specify 00).
A dot (•) denotes unrestricted availability. A letter denotes restricted availability.
Restrictions follow Table IV.

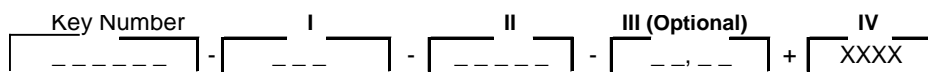

KEY NUMBER			Selection	Availability	
	Design	Span			
Absolute	Single	0-50 to 0-780 mm HgA/0-67 to 0-1040 mbarA	STA122	↓	
Pressure	Head	0-5 to 0-500 psi/0-0.34 to 0-35 bar absolute	STA140		↓

TABLE I - METER BODY

	Wetted Process Heads	Vent/Drain Valves **	Barrier Diaphragms			
Materials of Construction	Carbon Steel *	-	316 LSS	A _ _	•	•
	Carbon Steel *	-	Hastelloy C	B _ _	•	•
	Carbon Steel *	-	Monel	C _ _	•	•
	316 St. St.	-	316 LSS	E _ _	•	•
	316 St. St.	-	Hastelloy C	F _ _	•	•
	316 St. St.	-	Monel	G _ _	•	•
	Hastelloy C	-	Hastelloy C	J _ _	•	•
Fill Fluid	Monel	-	Monel	L _ _	•	•
	Silicone DC200 ****			_ 1 _	•	•
	CTFE			_ 2 _	•	•
Process Head	9/16" - 18 Aminco			_ _ A	•	•
Configuration	1/2 NPT (female)			_ _ G	•	•

* Carbon Steel heads are zinc-plated. Not recommended for water service due to hydrogen migration. Use Stainless Steel heads.

** Vent/Drains are Teflon coated for lubricity.

**** If STA122 operating below 50mm HgA, see Figure 2 in Specification 34-ST-03-61 and contact Marketing Applications for a "Special" Silicone DC704 quote.

Model Selection Guide, continued

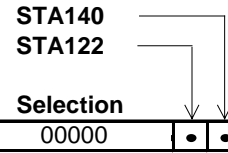

TABLE II

No Selection	00000	•	•
--------------	-------	---	---

TABLE III - OPTIONS

None	00	•	•	
Mounting Bracket - Carbon Steel	MB	•	•	b
Mounting Bracket - ST. ST.	SB	•	•	
Flat Mounting Bracket - Carbon Steel	FB	•	•	
Viton Process Head Gasket (Teflon is standard)	VT			
Teflon Process Head Gasket (Viton is standard)	TF	•	•	
Analog Meter (0-100 Even 0-10 Square Root)	ME	•	•	b
Smart Meter	SM	•	•	
Modified DIN Process Heads - 316SS	DN	w	w	
316 ST.ST. Electronics Housing with M20 Conduit Connections	SH	n	n	b
1/2" NPT to M20 316SS Conduit Adapter (BASEEFA EEx d IIC)	A1	n	n	
1/2" NPT to 3/4" NPT 316 SS Conduit Adapter	A2	u	u	
Lightning Protection	LP	•	•	
Custom Calibration and I.D. in Memory	CC	•	•	
Transmitter Configuration - non-Fieldbus	TC	•	•	b
Transmitter Configuration - Fieldbus	FC	a	a	
Write Protection	WP	•	•	
A286SS (NACE) Bolts and 302/304SS (NACE) Nuts for Head	CR	•	•	
Stainless Steel Customer Wired-On Tag (4 lines, 28 characters per line, customer supplied information)	TG	•	•	
Stainless Steel Customer Wired-On Tag (blank)	TB	•	•	
Clean Transmitter for Oxygen or Chlorine Service with Certificate	OX	h	h	
Over-Pressure Leak Test with F3392 Certificate	TP	•	•	
Additional Warranty - 1 year	W1	•	•	b
Additional Warranty - 2 years	W2	•	•	
Additional Warranty - 3 years	W3	•	•	
Additional Warranty - 4 years	W4	•	•	
Calibration Test Report and Certificate of Conformance (F3399)	F1	•	•	b
Certificate of Conformance (F3391)	F3	•	•	
Certificate of Origin (F0195)	F5	•	•	
NACE Certificate (F0198)	F7	o	o	
FOUNDATION Fieldbus Communications	FF	r	r	b
HART Protocol compatible electronics	HC	e	e	

Model Selection Guide, continued

Approval Body	Approval Type	Location or Classification	Selection	STA140	STA122
No hazardous location approvals			9X	a	.
Factory Mutual	Explosion Proof	Class I, Div. 1, Groups A,B,C,D	1C	a	.
	Dust Ignition Proof	Class II, III Div. 1, Groups E,F,G			
	Non-Incendive	Class I, Div. 2, Groups A,B,C,D			
	Intrinsically Safe	Class I, II, III, Div. 1, Groups A,B,C,D,E,F,G			
CSA	Explosion Proof	Class I, Div. 1, Groups B,C,D	2J		.
	Dust Ignition Proof	Class II, III, Div. 1, Groups E,F,G			
	Intrinsically Safe	Class I, II, III, Div. 1, Groups A,B,C,D,E,F,G			
Zone 2 (Europe)	Self-Declared per 94/9/EC (ATEX4)	Ex II 3 GD T ⁽¹⁾ X (1) T4 at Tamb. 93°C, T5 at Tamb. 80°C, T6 at Tamb. 65°C	3N	.	.
SA (Australia)	Intrinsically Safe	Ex ia IIC T4	4H	a	a
	Non-Incendive	Ex n IIC T6 (T4 with SM option)			
	Flame Proof	Ex d IIC T6			
LCIE	Flame Proof/ CENELEC	EEx d IIC T6	3A		.
	Intrinsically Safe/ CENELEC	EEx ia IIC T5			
	Flame Proof/ CENELEC	EEx d IIC T6	3D	.	.

TABLE IV

Factory Identification	XXXX	.	.
------------------------	------	---	---

RESTRICTIONS

Restriction Letter	Table	Available Only With Selection	Table	Not Available With Selection
a		Pending		
b		Select only one option from this group		
e	III	1C, 2J, 3N, 3D, 9X		
h		_ 2 _		
n			III	1C, 2J
o	III	CR		
r			III	TC, ME
u	III	1C, 2J		
w	I	E _ G, F _ G, G _ G		

Note: See 13:ST-27 for Published Specials with pricing.
 See 13:ST-29 and User's Manual for part numbers.
 See 13:ST-OE-9 for OMS Order Entry Information including TC, manuals, certificates, drawings and SPINS.
 See 13:ST-OD-1 for tagging, ID, Transmitter Configuration (TC) and calibration including factory default values.
 To request a quotation for a non-published "special", fax RFQ to Marketing Applications.

