

Mobrey MLT100

Displacer level transmitter

Data sheet
IP119

MLT100 transmitter

- Level, contents or interface measurement.
- Direct or external cage mounting

Features

- 2 wire 24v dc loop powered
- 4-20mA output
- HART communications :-
- EExd or EExia certification
- Simple local or remote calibration
- Non-interactive Zero and Span
- High temperature remote electronics option
- Option of local indicator
- Range of wetside materials

Description

The Mobrey MLT100 Level Transmitter is one of the most advanced displacer based devices on the market, coupling the time proven buoyancy principle with state of the art electronics in an instrument of high reliability and stability.

Special care has been taken in design to ensure a small mounting envelope is maintained, resulting in reduced weight and associated savings in mounting. The displacer element is made to length for each order, and is suspended below the head on a stable spring arrangement which is designed to minimise friction effects and improve performance.

The transmitter can be mounted directly into a vessel or may be externally mounted in a chamber to allow isolation for planned maintenance or in-situ calibration checks.

Operation

The 4 - 20 mA output from the head is proportional to the level or contents in the vessel, or may be set to follow an interface.

SMART electronics mean digital communication is possible. The Mobrey transmitter supports the HART protocol, which is superimposed on the 4-20mA signal. Thus the user can operate the transmitter without digital communications, or can take advantage of the many features of HART such as remote calibration, re-ranging, on-line diagnostics and multidrop installations.

Typical applications

The Mobrey MLT will operate in most level measurement applications including :-

- Knock-out pots
- Condensate drums
- Separators
- Flash vessels
- Storage vessels
- Receiver tanks

Operating wetside temperatures are -60°C to +320°C at pressures between full vacuum and 200 bar. Remote electronics models available for high temperature and nuclear applications*. Most liquids can be measured, with wetted materials chosen to suit. The liquid SG range is from 0.5 to 1.5, and interfaces with as low an SG difference of 0.1 are also practical. The range of the instrument is dependent only upon the length of the element specified, although 3000mm is considered the longest standard length.

* Remote electronics models are available to special order.

Approvals

ATEX II 1/2 GD EEx d IIC T6
Tamb = -40°C to +75°C
ATEX II 1 G D EEx ia IIC T5
Tamb = -40°C to +40°C
ATEX II 1 G D EEx ia IIC T4
Tamb = -40°C to +80°C

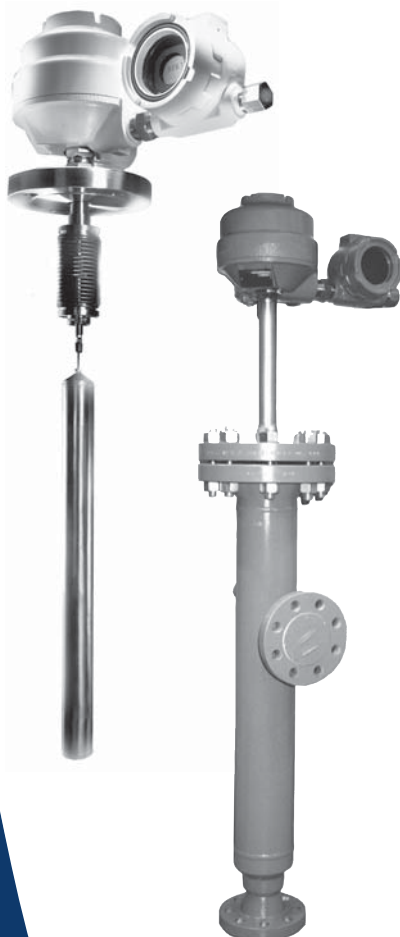

Operation

Changes of liquid level in the vessel cause the displacer element, which is supported on a spring, to rise or fall.

A core, located in the pressure tube of the head, is connected to the displacer and moves linearly up and down with the element. Around the outside of the pressure tube in the head is a Linear Variable Differential Transformer (LVDT), the output of which is proportional to the position of the core. The pressure tube is made of stainless steel and is welded to the union which connects the head to the process pressure and temperature.

The displacer length is dictated by the operating range requested, and the diameter and weight are factory calculated to ensure the correct operating movement of the core in the head.

Sophisticated surface mount electronics process the voltage signal from the LVDT into a 4-20mA output signal.

Each transmitter is fitted with a visible LED which flashes once every 3 seconds to show the instrument is healthy and working.

Field adjustments

Calibration

The transmitter is set up by Solartron Mobrey to operate in the conditions advised at the time of order, and the displacer element dimensions are chosen to suit. Provision is made for the customer to check this calibration once on site. A manual fine tune adjustment may be made with the instrument in an empty vessel at 20°C which will ensure correct readings at operating conditions.

Local calibration

Several adjustments can be made in the field using the unique "Mobrey Magnetic Scroller" (MMS) and the "Caliplug". The MMS is a calibration tool with a magnetic tip, and is used on this and other Solartron Mobrey instruments to access and adjust certain operating parameters. The level transmitter is fitted with a calibration plug (Caliplug) which

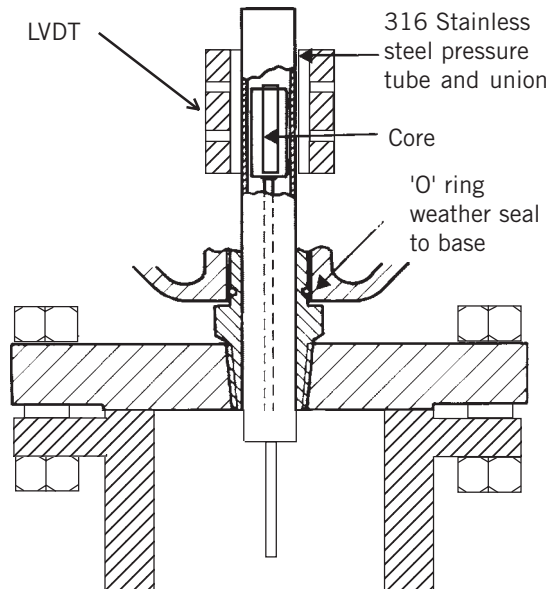

contains docking ports for the MMS along with the heartbeat LED. The adjustments which may be made are as follows :-

Setting the 4mA and 20mA points

This can be carried out locally at the transmitter by using the MMS to "zero" the device with the level at the required 4mA point, then to "Span" the device with the level at the 20mA point. The Zero and Span settings are non-interactive. An additional feature is the ability to span the instrument in the same way but without the vessel being filled to the 20mA point. In this case, the vessel is filled to a known level and the output incremented to give the required mA level. The 20mA point is then electronically calculated by the instrument.

Setting the damping

The user can field set the damping (smoothing or response time) using the MMS, to a value up to 100 seconds.

Remote calibration

(not necessary for standard 4 -20 mA operation).

Alternatively, the ranging can be carried out using a "SMART Communicator" by simply establishing digital communications and setting the 4 and 20mA points electronically (without the need for changing the liquid level) using HART protocol.

Local indication (optional)

A multi-function LCD indicator housed in a cast aluminium Exd enclosure, finished in two pack epoxy white paint. The 2-line LCD display can be programmed to show output

in %, engineering units and other operating parameters using the smart communicator.

Construction

Transmitter head

The transmitter head is manufactured from cast iron with a paint finish of two pack Epoxy white paint suitable for offshore or coastal use.

Weatherproof rating IP66 / IP67.

Wetted parts are made from stainless steel, including the element, trim and pressure tube, except for the spring which is manufactured from a specialist corrosion resistant spring material, NIMONIC, chosen for its stability and repeatability under changing process conditions.

Chamber (when specified)

The material used will be to the customer's specification or to suit the application. Only certified materials are used, and welding is qualified to ASME IX, BS EN 287 and BS EN 288.

All pressure retaining parts are hydrostatically pressure tested to a minimum of 1.25 times working pressures.

NDT including radiography & dye penetrant testing is available when specified at time of order. Inspection by customers or their appointed agents is welcome provided this is requested at time of order.

Options:

Wetside materials in Hastelloy, Inconel and others on request.

Compliance with NACE MR-01-75 for sour service duty.

Ordering information

MLT	Mobrey Level Transmitter										
	Code	Flange material									
	C	Carbon steel							N	No flange (1" NPT connection)	
	S	Stainless steel									
	Code	Flange mounting									
	60	3" ANSI # 150 RF				65	4" ANSI # 150 RF				
	61	3" ANSI # 300 RF				66	4" ANSI # 300 RF				
	62	3" ANSI # 600 RF				67	4" ANSI # 600 RF				
	63	3" ANSI # 900 RF				68	4" ANSI # 900 RF				
	64	3" ANSI # 1500 RTJ				69	4" ANSI # 1500 RTJ				
	71	DN80 PN16				76	DN100 PN16				
	72	DN80 PN25				77	DN100 PN25				
	73	DN80 PN40				78	DN100 PN40				
		00				No flange					
	Code	Head variations : Weatherproof IP66/IP67									
	TS	IS ATEX				TF	EExd ATEX				
	TR	Remote electronics, to special order. Note : electronics in safe area only.									
	Code	Pressure tube type: Select from graph overleaf									
	A	Std (up to 224°C condensing)				B	High temperature : over 224°C & up to 277°C condensing, 320°C non-cond, remote electronics to 320°C condensing.				
	Code	Display									
	D	With display				N	Without display				
	Code	Spring									
	*	The code number for the spring will be entered at time of quote/order									
	Code	Displacer									
	*	Code number for displacer will be entered at time of quote/order									
	Code	Chamber - type & orientation									
	A	Not required									
	B	Side/bottom with no vent									
	C	Side/bottom with ½" NPT vent									
	D	Side/bottom with ¾" NPT vent									
	F	Side/bottom with ¾" flanged vent									
	G	Side/side with ½" NPT drain & no vent									
	H	Side/side with ¾" NPT drain & no vent									
	J	Side/side with 1" NPT drain & no vent (std)									
	K	Side/side with ½" NPT drain & vent									
	L	Side/side with ¾" NPT drain & vent									
	M	Side/side with 1" NPT drain & vent									
	N	Side/side with ¾" drain & no vent									
	P	Side/side with ¾" flanged drain & ¾" NPT vent									
	Q	Side/side with ¾" flanged drain & ¾" flanged vent									
	Code	Chamber process connections									
	11	1" ANSI # 150 RF				25	DN40 PN16				
	12	1" ANSI # 300 RF				26	DN40 PN25				
	13	1" ANSI # 600 RF				27	DN40 PN40				
	14	1" ANSI # 900 RF				31	2" ANSI # 150 RF				
	18	1" ANSI # 1500 RTJ				32	2" ANSI # 300 RF				
	15	DN25 PN16				33	2" ANSI # 600 RF				
	16	DN25 PN25				34	2" ANSI # 900 RF				
	17	DN25 PN40				38	2" ANSI # 1500 RTJ				
	21	1.5" ANSI # 150 RF				35	DN50 PN16				
	22	1.5" ANSI # 300 RF				36	DN50 PN25				
	23	1.5" ANSI # 600 RF				37	DN50 PN40				
	24	1.5" ANSI # 900 RF				01	Screwed 1" NPT				
	28	1.5" ANSI # 1500 RTJ				00	Chamber not supplied				
LT	C	61	TS	A	D	3	A	B	11	Typical ordering information	

The following information must be supplied at time of order :-

- Operating pressure, temperature, specific gravities (upper / lower), viscosity
- Liquid and nature of vapour :condensing or non-condensing - Maximum or design pressures and temperatures
- Ambient temp. and local environmental conditions - Operating range. (This will be taken as the process connection centres unless otherwise stated)
- Mounting arrangement and any specific materials of construction required. If a chamber is required, please specify all relevant dimensions. In addition to the above standard configurations, chambers may be made to special order.
- Any options : Meter, chamber connections or vent/drain, special paint, inspection and NDT requirements, or other.

Dimensions : IP66 / IP67 transmitter head

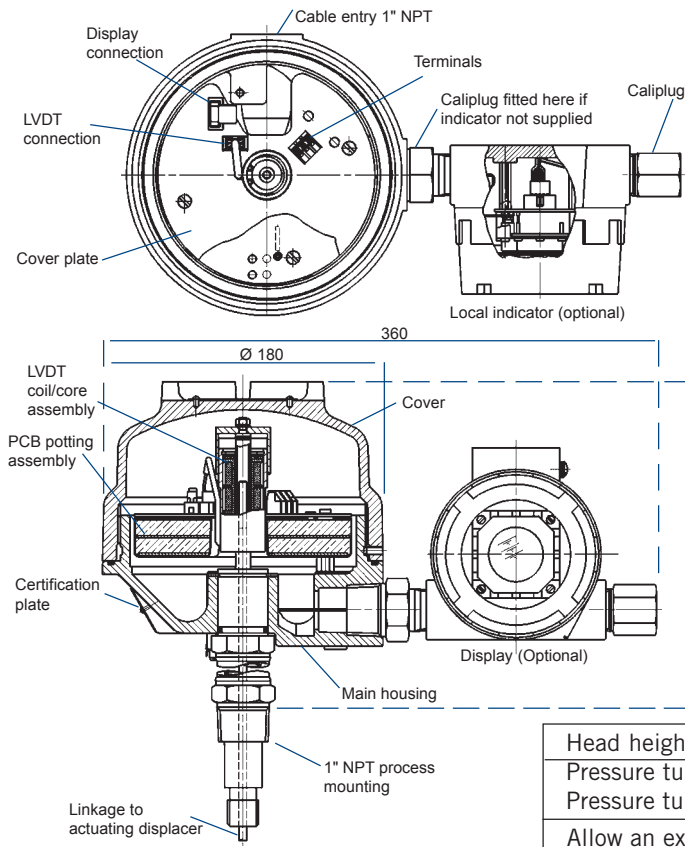

Head height	H
Pressure tube A	200
Pressure tube B	422
Allow an extra 90 for cover removal	

Pressure tube type selection

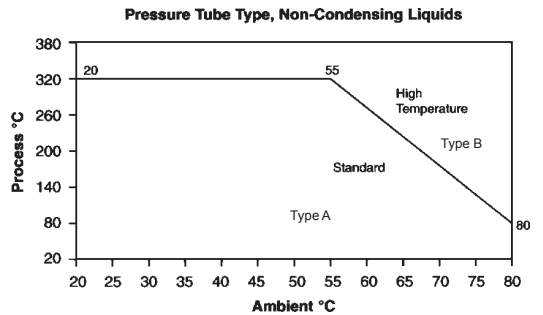
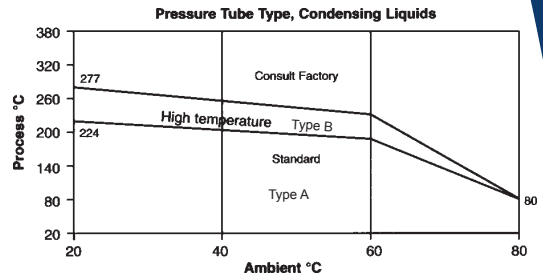

Mobrey Palm style Hand Held Communicator

The HPC allows full access to all of the MLT100 parameters. Ordering information: MHC-HPC. See brochure IP2037 for full details.

Mobrey Universal Hand Held Communicator

The Universal HHC can be programmed with the Device Description (DD) of any registered HART device and will then allow full access to all of the instrument parameters.

Mobrey H-Conf401

A Windows based PC programming tool which allows full communication with Solartron Mobrey HART products. H-Conf401 gives access to all of the instrument parameters, allowing programming and interrogation. See brochure IP2037 for full details.

Specification

Output	4 - 20mA SMART/HART digital	Ambient temp.	-40 to +80°C (Subject to process temperature)
Range	300 - 3000mm to order	Accuracy	< +/- 1% output span
Max. operating pres.	200 bar	Repeatability	+/- 0.2% of output span
Min operating pres.	Full vacuum	Linearity	0.2% of output span
SG range	standard 0.5 to 1.5 interface 0.1 diff.	Resolution	0.1% of output span
Max. operating temp.	320°C non-condensing 320°C condensing with remote electronics	Hysteresis	0.3% of output span
Min. operating temp	-60°C	Power supply	12-40V dc loop powered
		Turndown	3 : 1
		Power consumption	21mA/40V : 840mW max

Reference List : Mobrey MLT100 transmitters are used all over the world by major organisations including SHELL UK, National Iranian Oil Co., Kuwait National Oil Co., Qatar General Petroleum, Conoco, GEC Alstom.

Solartron Mobrey Limited

158 Edinburgh Avenue Slough Berks UK SL1 4UE
Tel: 01753 756600 Fax: 01753 823589
e-mail: sales@solartron.com www.solartronmobrey.com



Solartron Mobrey GmbH	Deutschland	tel: 0211/99 808-0
Solartron Mobrey sp z oo	Polska	tel: 022 871 7865
Solartron Mobrey AB	Sverige	tel: 08-725 01 00
Solartron Mobrey SA	France	tel: 01.30.17.40.80
Solartron Mobrey SA-NV	Belgium	tel: 02/465 3879
Solartron Mobrey Ltd	China	tel: 021 6353 5652
Solartron Mobrey	USA	tel: (281) 398 7890

The right is reserved to amend details in this publication without notice

